

Steering LS 5F / LS 7F

Order No. 6460 5011 02

46.7 Steering LS 5 F / LS 7 F (765.2 / 3)

	Job. No.	
Illustrations, Exploded Views	-	46.7 - 003/1
Special Tools	-	46.7 - 004/1
Technical Data, Oil Capacity	-	46.7 - 005/1
Maintenance Work	-	46.7 - 010/1
Notes regarding replacing steering following an accident	-	46.7 - 015/1
Testing power steering pump	-	46.7 - 020/1
A Connecting and disconnecting test set	-	46.7 - 020/1
B Connection diagram	-	46.7 - 020/3
C Testing pump pressure	-	46.7 - 020/4
D Testing delivery	(46-3390)	46.7 - 020/4
Testing steering for pressure	(46-3080)	46.7 - 025/1
Testing steering for leak oil	(46-3100)	46.7 - 030/1
Checking and adjusting center position	(46-3015)	46.7 - 035/1
Adjusting pitman arm shaft	(46-3230)	46.7 - 040/1
Bleeding steering, checking and correcting oil level	(46-3300)	46.7 - 045/1
Checking and adjusting steering limit valves	(46-3220)	46.7 - 050/1
Removing and installing steering	(46-3400)	46.7 - 055/1
Renewing hydraulic lines	(46-5610)	46.7 - 060/1
Checking steering components	(46-3005)	46.7 - 065/1
Removing and installing pitman arm shaft	-	46.7 - 070/1
A Removing and disassembling pitman arm shaft ...	-	46.7 - 070/2
B Disassembling and assembling housing cover ...	-	46.7 - 070/4
C Removing pitman arm shaft mounting from and installing in steering housing	-	46.7 - 070/5
D Assembling and installing pitman arm shaft	-	46.7 - 070/7
Removing, disassembling and assembling steering worm and working piston	-	46.7 - 075/1
A Removing working piston	-	46.7 - 075/4
B Disassembling and assembling steering worm bearing	-	46.7 - 075/4
C Disassembling and assembling working piston and steering nut	-	46.7 - 075/12
D Installing steering worm with bearing into working piston	-	46.7 - 075/19
E Installing working piston with steering worm	-	46.7 - 075/20
Removing, disassembling, assembling and installing valve spool	-	46.7 - 080/1
A Model designation 765.200 and 765.300	-	46.7 - 080/1
B Model designation 765.208	-	46.7 - 080/6
Removing and installing non-return valve	-	46.7 - 085/1

Note:

In the Federal Republic of Germany and in a number of other countries, certain parts for installation or attachment are approved only if they comply with applicable statutory provisions. This requirement is met in all cases by Mercedes-Benz Genuine Parts. Use of other parts may invalidate the vehicle registration.

The Part Numbers stated are intended only to identify and distinguish individual versions. When ordering replacement parts, always refer to the parts documentation for Part Numbers.

Reproduction or translation, in whole or in part, and other copying of this microfilm, regardless of type, is not permissible without our explicit written approval.
Invalid microfilms should be destroyed immediately.

Mercedes-Benz AG
D-70322 Stuttgart
Werk Wörth, VN / SP

Made in Federal Republic of Germany

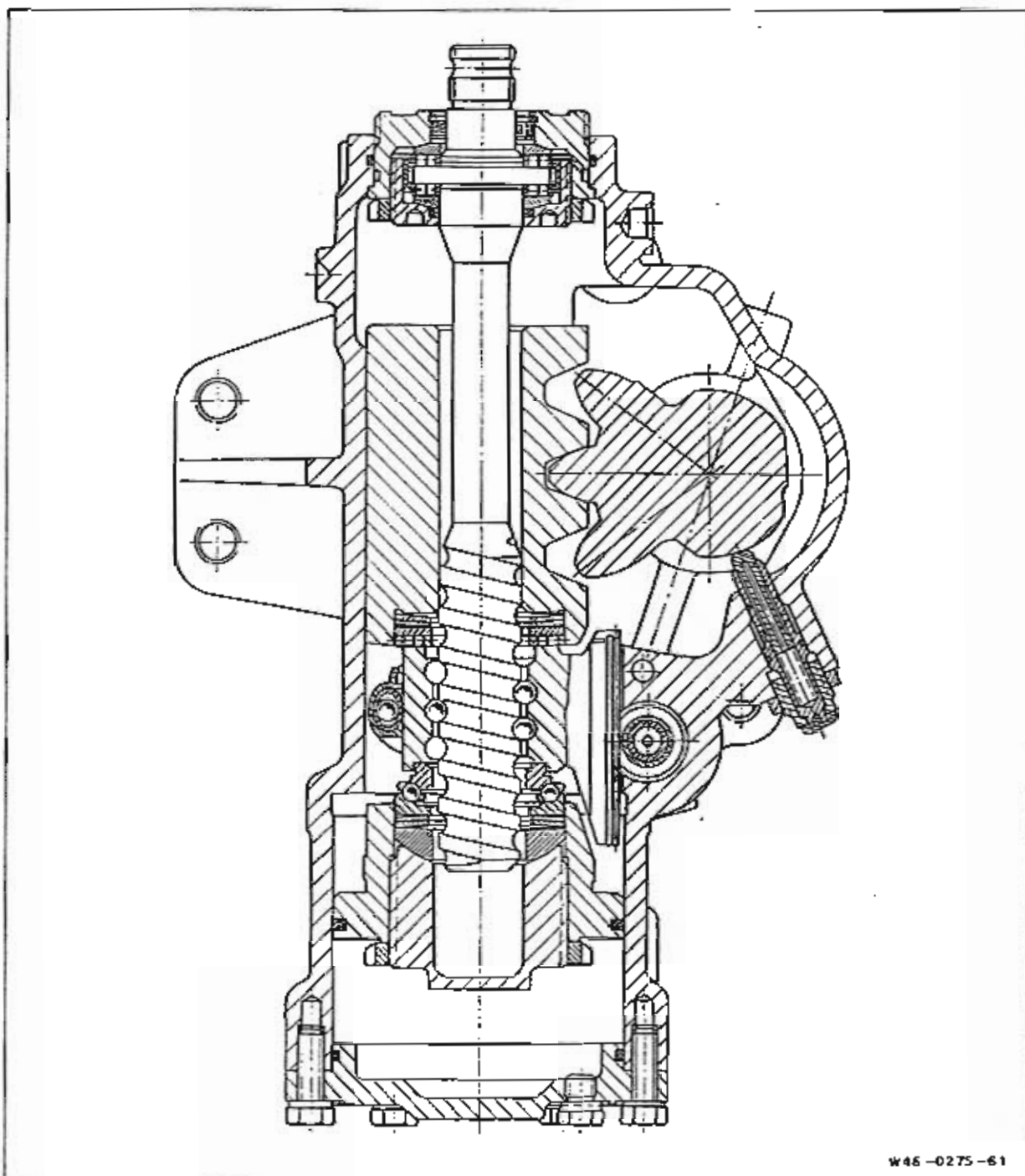

Steering LS 5 F

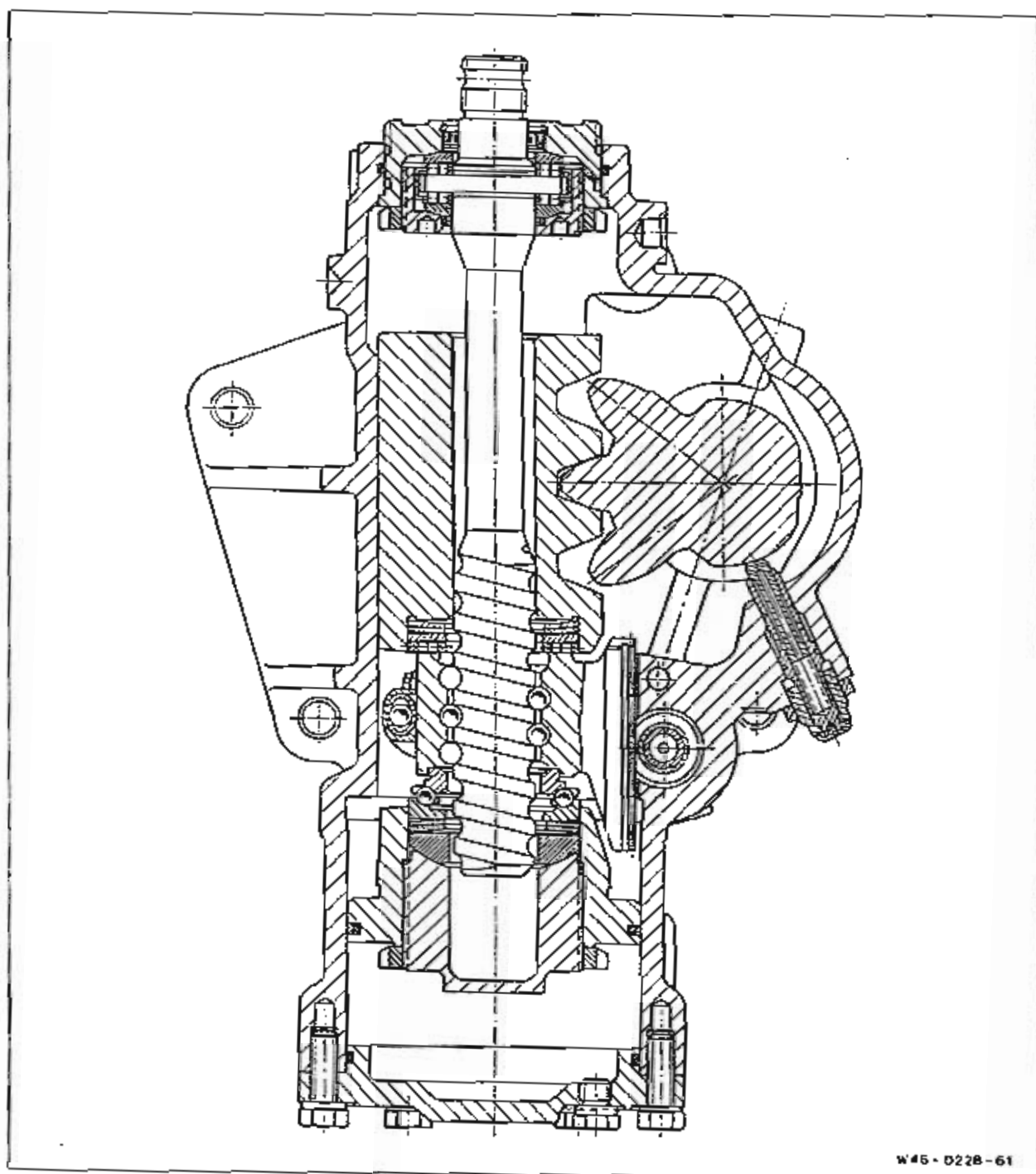

W46 - 0228 - 61

Steering LS 7 F

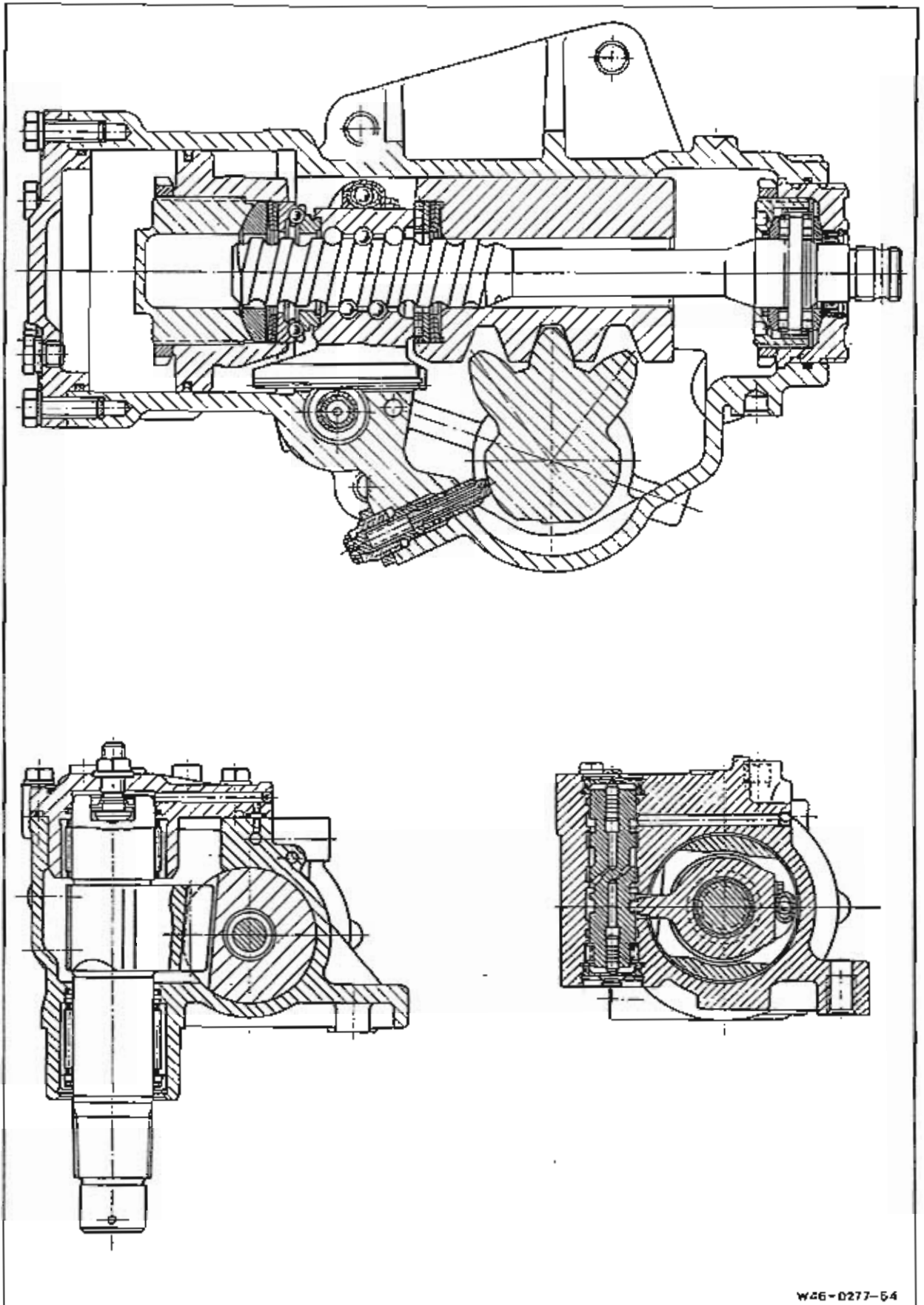

W46-0277-54

LS 5 F, Steering Model Designation 765.200
LS 7 F, Steering Model Designation 765.300

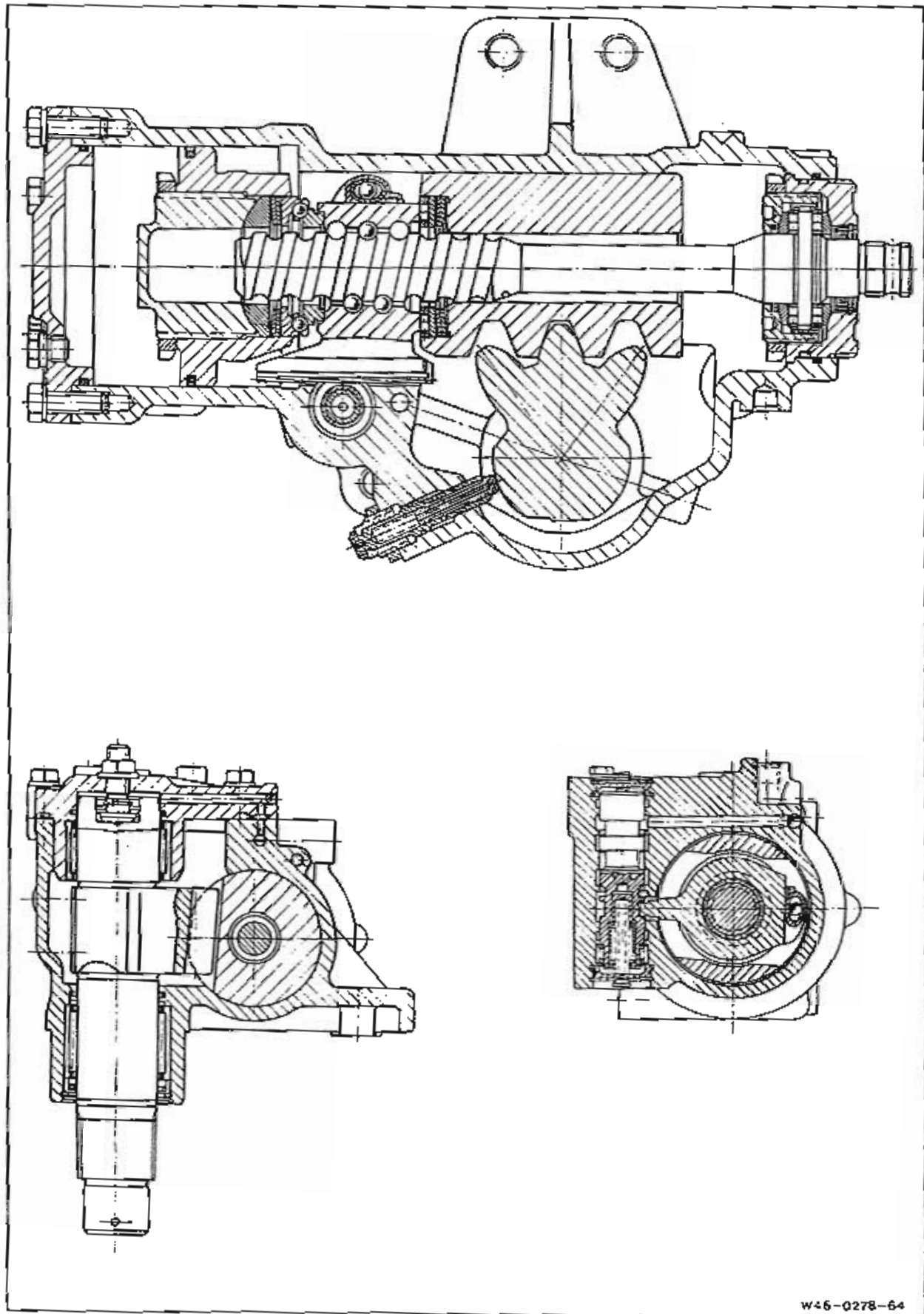

LS 5 F, Steering Model Designation 765.208

46.7-004 Special Tools

Designation	Part Number
Fork wrench (wal 65)	000 589 16 01 00
Fork wrench (wal 70)	000 589 17 01 00
Wrench socket	385 589 01 03 00
Pronged wrench	352 589 01 07 00
Pronged wrench	352 589 02 07 00
Adjusting wrench	387 589 03 07 00
Hexagon pin wrench	001 589 61 09 03
Mandril	352 589 04 15 00
Mandril	360 589 00 15 00
Test set	001 589 37 21 00
Torque wrench	000 589 64 21 00
Dial gauge	001 589 63 21 00
Torque wrench	001 589 80 21 00
Test device	363 589 01 21 00
Dial gauge holder	363 589 02 21 00
Bending device	000 589 39 31 00
Assembly device	315 589 02 31 00
Assembly device	352 589 00 31 00
Retaining wrench	387 589 00 31 00
Internal extractor	000 589 30 33 00
Counter-support	000 589 34 33 00
Puller	363 589 01 33 00
Puller	601 589 04 33 00
Assembly sleeve	352 589 01 61 00
Handwheel	352 589 08 63 00

46.7-005 Technical Data, Oil Capacity

Technical Data

Steering	LS 5 F	LS 7 F
Ratio	19.33:1	21.78:1
Total number of turns of steering worm	4.85	5.63
Working piston travel	2 x 31.5 mm	2 x 42.2 mm
Theoretical hydraulic torque at pitman arm shaft at 100 bar	4 300 Nm	5 590 Nm
Pitch of steering worm	13 mm	15 mm
Steering designed up to max. front axle load	6 300 kg	7 500 kg
Theoretical max. pitman arm shaft torque angle	90°	93°
Working piston dia.	117 mm	117 mm
No. of steel balls in recirculating ball assy.	28	28

Oil Capacity

ATF or transmission oil ¹⁾	2.8 l	3.8 l
---------------------------------------	-------	-------

¹⁾ see "MB Service Product Specifications" Sheet No. 236.2 / 3 / 6 / 7

Checking for leaks

- 1 Check entire steering system (steering housing, pump, oil reservoir) as well as all connections and joints for signs of leaks; seal, if necessary.
- 2 Tighten line connections. Renew seals. When performing these steps, check hoses and lines to ensure they are properly fixed and not chafing; renew any damaged parts.

Checking play and wear

- 1 Check ball joints of tie rod and drag link for axial play; if excessive play exists, renew joints. Replace leaking and damaged protective caps.
- 2 Check mounting of steering idler arm for play and wear. Renew worn parts.

Checking mounting of steering and transmission parts

- 1 Shake steering wheel and check the mounting of the steering spindle bearing.
- 2 With engine running, turn steering wheel from full left to full right lock – applying force and relieving force several times – while at the same time checking that the following parts are tight, steering at steering bracket, steering bracket to frame, pitman arm, tie rod and drag link arm, steering brackets of steering idler arms and steering idler arms.
- 3 Tighten nuts and bolts, if necessary.

Replacing steering

Aggravated operation	every 300 000 km
short- and long-haul operation	every 450 000 km

See removing and installing steering
(46.7-065).

A. Assessing steering of vehicle damaged in an accident

1 If a vehicle has suffered damage to bodywork in an accident (e. g. deformed mudguards, side members, platform, bodies, side panelling, rear sections etc.), the steering may be re-used provided that

- a) front axle components such as front axle beam, steering knuckle, control arm, tie rod and drag link, pitman arm, steering knuckle arm and steering idler arm are not damaged and the pitman arm shaft does not display any twisting at the splined section.
- b) the front axle has not suffered excessive stress or there is no reason for assuming this.
- c) the steering can be rotated at the steering joint by hand from stop to stop without any signs of sticking.

2 For reasons of safety, the steering should be renewed if

- a) parts of the front axle or of the steering linkage have been permanently deformed,
- b) the front axle has been subjected to excessive stress as confirmed by the results of measuring chassis alignment.

B. Costs of steering when performing repairs to a vehicle damaged in an accident

The cost settlement procedures are described in detail in Circular No. 23/84 of VOI dated 3.4.84 Organisation Manual No. 3.10.1/7.8.3/7.9.1 under the title "Procedure for accident damage to passenger car in commercial vehicle steering when performing repairs".

C. General

Attention should be paid to the following points when assessing accident damage to steering:

If the damage involves an insurance claim, we recommend discussing the decisions and procedures with the relevant insurance company or with the authorized insurance assessor. Damage, which is not externally visible, may be caused as a result of an impact which is transmitted through the steering linkage to the steering. For this reason, it is essential to examine the complete steering system by means of a visual inspection and crack test. As such an inspection cannot be performed in the majority of workshops, the steering should be replaced where doubt exists.

Should the insurance assessor be of the opinion that the steering can remain fitted to the vehicle, contrary to the opinion of the responsible workshop personnel, we recommend having the insurance assessor confirm his decision by his signature.

If, in exceptional cases, the request is made to inspect the steering and note the findings (e. g. at the request of the insurance company if the steering has been stated as the cause of the accident), the insurance assessor or authorized representative of the insurance company must be asked to complete a separate order form. The workshop can then return the steering with a returned goods delivery note for examination to

Mercedes Benz
Werk Düsseldorf
Abladestelle 436 Garantiekontrolle
Postfach 300265
D-4000 Düsseldorf 30

The Düsseldorf Plant is not able, however, to conduct one-off reconditioning. For this reason, the customer must specify whether

- the steering is to be returned provisionally assembled to the sender
- the steering is to be scrapped
- the steering is to be reconditioned as an exchange steering with the returned value being credited.

The examination and findings shall be invoiced to the customer

In export countries, such orders should be handled through the relevant General Distributor or Service Head Office.

Special tool



Data

Hydraulic oil temperature	50 °C
Delivery of power steering pump at 600 rpm	8 l ^{+20%} -10%

A Connecting and disconnecting test set

Connecting

- 1 Detach delivery line from power steering pump to steering, link connection 1 on test set to the pump and connection 2 to the steering.
- 2 Detach return line from the steering to the oil reservoir, link connection 3 on the test set to the steering and connection 4 (transparent line) to the oil reservoir.
- 3 Set both levers on the tester to "zero".
- 4 Fill reservoir with oil and bleed steering system (46.7-045).
- 5 Continue running engine until the oil has heated up to approx. 50 °C. Take oil temperature reading at thermometer of tester.

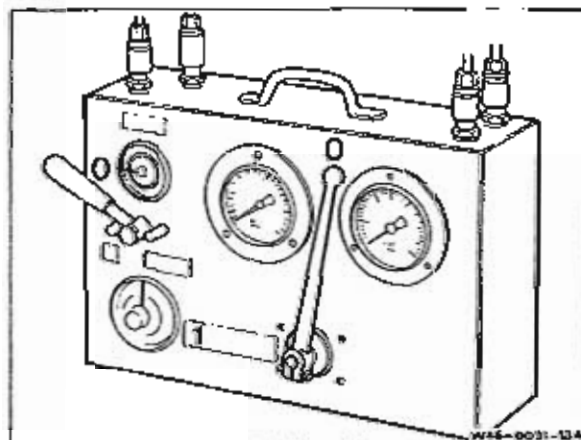

Tester 001 589 37 21 00

Disconnecting

- 1 Connect delivery line from the pump to the steering and return line from the steering to the oil reservoir.
- 2 Fill reservoir with oil, bleed steering system and check for leaks.
- 3 Test run: When performing test run, check the entire steering performance of the vehicle.

B Connection diagram

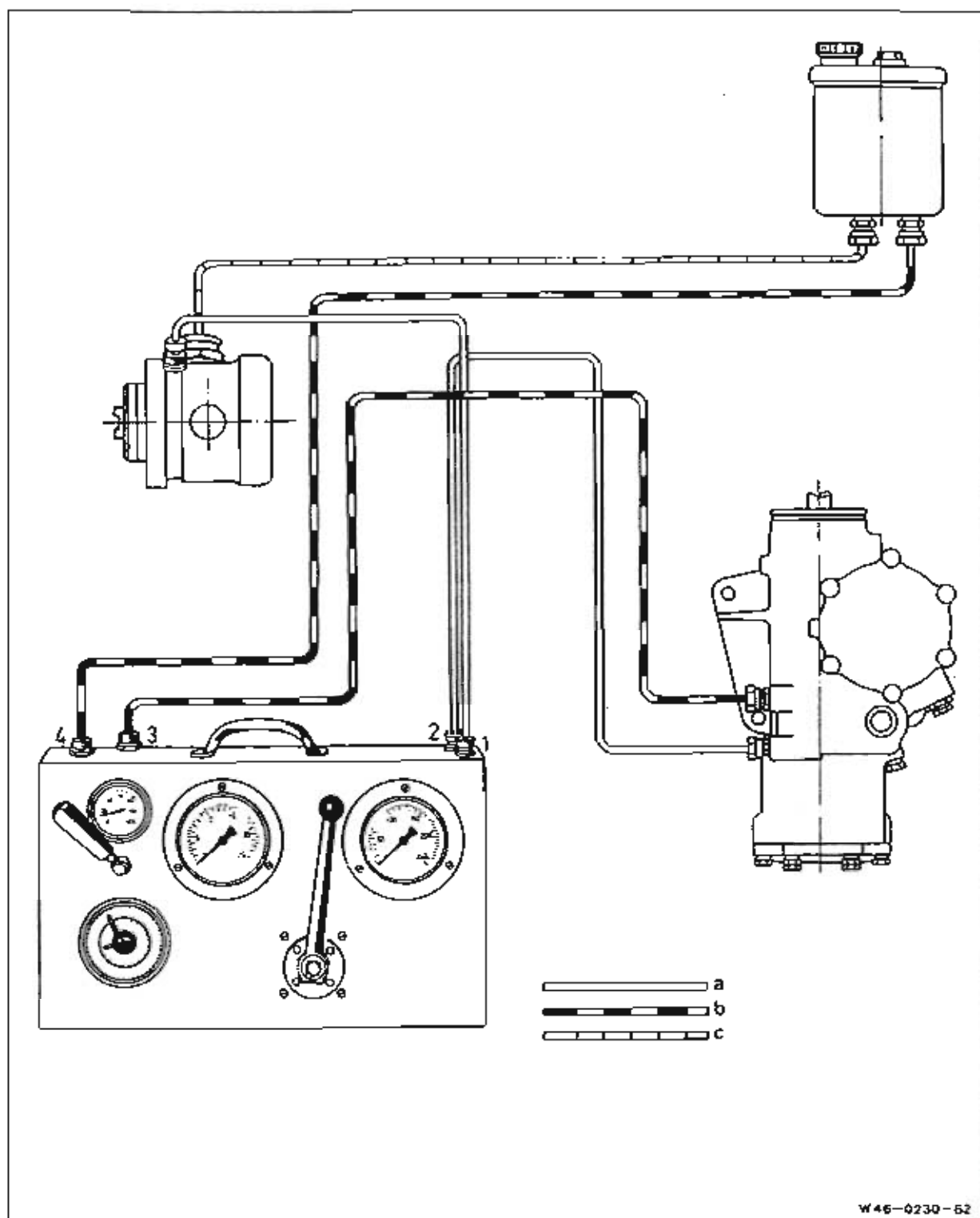

- 1 Connection of high pressure hose to power steering pump
 - 2 Connection of high pressure hose to steering
 - 3 Connection of return hose to steering
 - 4 Connection of return hose to oil reservoir
- a Delivery line
b Return line
c Suction line

C Testing pump pressure

- 1 Start engine. Set idle speed to approx. 600 rpm.
- 2 The low pressure gauge (0 – 25 bar) of the tester indicates a flow pressure of 4 – 15 bar.
- 3 Briefly move the large lever on the tester from "zero" to position 1 (max. 5 s to avoid overheating pump).
- 4 Take reading at high pressure gauge (0 – 250 bar) of pressure produced by the pump. The pump pressure must not vary from the rated pressure stated on the type plate by more than $\pm 5\%$.

Tester 001 589 37 21 00

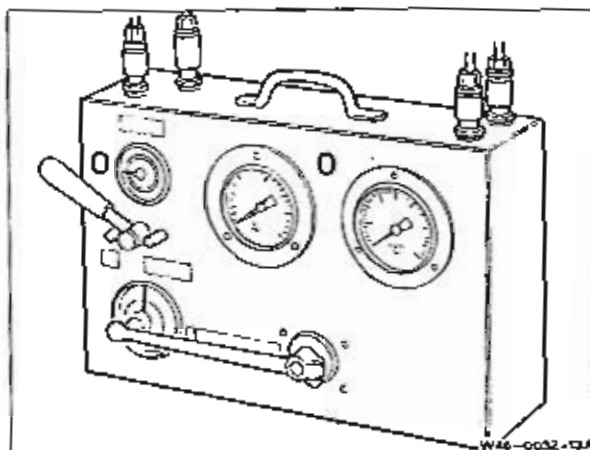

Note:

Read off rated pressure on the type plate of the power steering pump (arrow).

- 5 If the pressure levels are not reached, replace power steering pump.

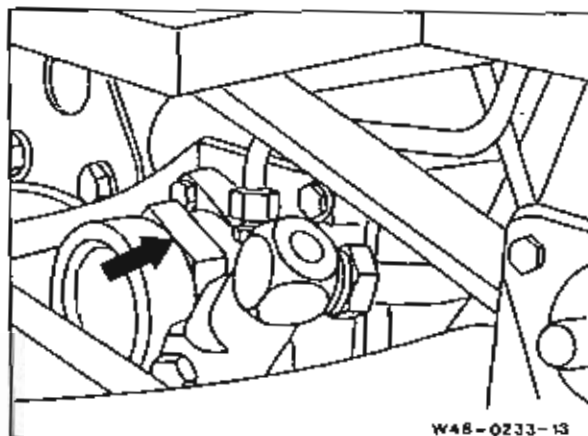

D Testing delivery

- 1 Test delivery of ZF hydraulic oil pump 7673 (at 600 rpm = 8 l).
- 2 To test the delivery at 600 rpm, move the small lever of the flow counter on the tester from "zero" to the right, hold in this position and at the same time start stopwatch.

Tester 001 589 37 21 00

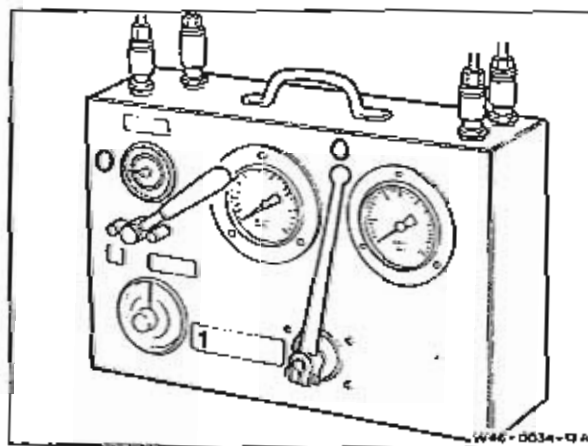

3 After 30 s, move lever back into "zero" position. Take the reading of the quantity which has been pumped through at the flow counter (bottom left scale) and multiply by 2 to obtain the delivery per minute.

Note:

If the required minimum levels for the pump are not achieved when testing delivery or pressure, the cause may be the following:

The combined flow control and pressure limiting valve is not operating.

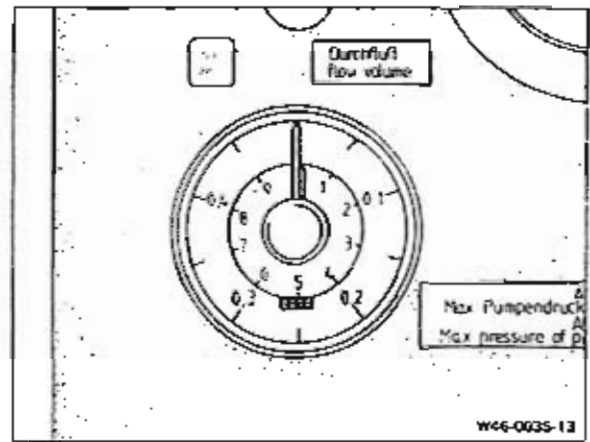

Remedy:

Remove valve and clean. Blow through restriction hole with compressed air. Re-install valve, paying attention to installation position.

Arrangement of ZF repair kit (hydraulic oil pump type 7673)

- 1 Valve
- 2 Compression spring
- 3 Washer
- 4 Screw plug

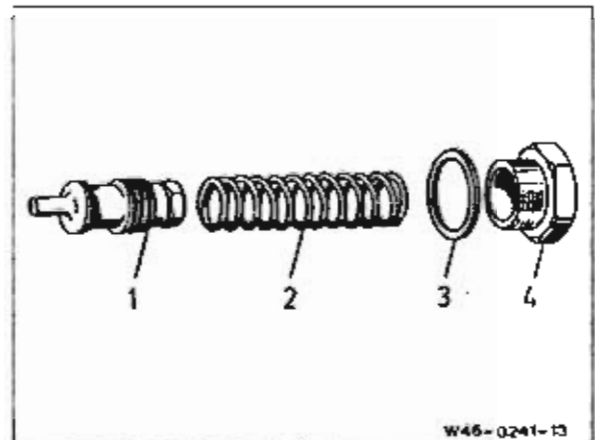

Arrangement of Vickers repair kit

- 1 O-ring
- 2 Valve
- 3 Compression spring
- 4 Roll pin

Note:

If, after performing this work, no increase in pump performance is detected, the pump must be replaced as the pump elements are excessively worn.

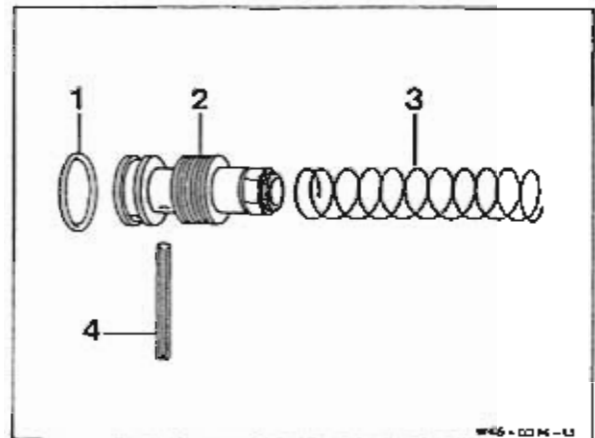

Special tool

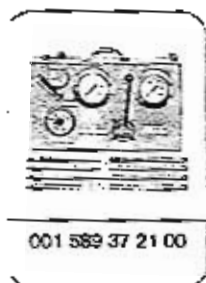

Testing steering for pressure

- 1 Move both levers on the test set to "zero".
- 2 Turn steering wheel to the left, push a sleeve of the left wheel stop bolt which switches off the hydraulic steering limiter.
- 3 Briefly (max. 5 s) pull the steering wheel to the left with a force of approx. 250 N (normal hand force).
- 4 Take the reading of the pressure obtained at the high pressure gauge (0 - 250 bar).
- 5 Perform the test also by turning steering wheel to the right. Determine pressure.

Note:

- The oil pressure which is obtained when performing each test must reach the maximum pressure of the pump which was measured previously.
- If, when turning steering wheel to the right or left or to both sides, it is found that the oil pressure is below the maximum pressure of the pump, conduct a test for leak oil.

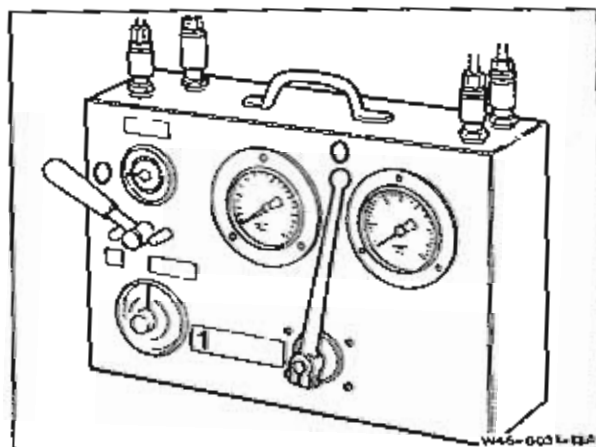

Tester 001 589 37 21 00

Special tool

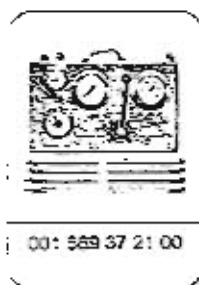

Data

Leak oil quantity

3.5 l

A leak oil test must be performed:

- if the specified maximum pressure of the pump is not reached when testing the steering for pressure.
- if the steering has been generally overhauled or internal components have been renewed.

Note:

Leak oil is oil which escapes at maximum working pressure at the high pressure seals at the working piston, steering shaft, valve spool and pitman arm shaft into the low pressure chamber, i. e. to the reservoir.

1 Turn steering to the right until the wheel stop bolt is touching the axle beam and pull the steering wheel with a force of approx. 250 N (normal hand force) so as to build up the maximum working pressure (indicated on high pressure gauge).

2 Move the small lever of the flow counter on the tester from "zero" to the right, hold in this position and at the same time start stopwatch.

3 After 6 s, move lever into "zero" position, release steering wheel.

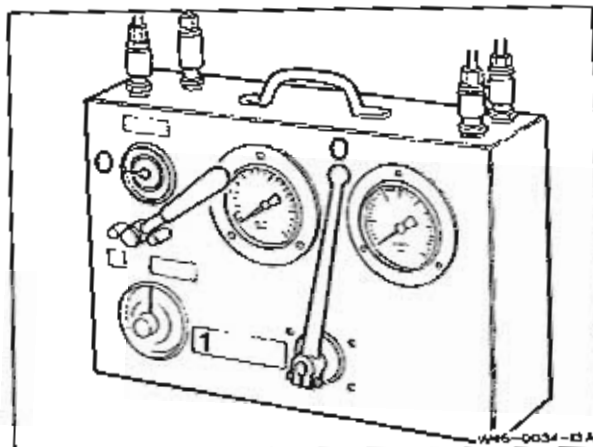

Tester 001 589 37 21 00

Note:

This sequence must be observed accurately in terms of time and in the order described in order to avoid incorrect measurements, overheating and overloading of the pump.

4 Take the reading at the flow counter of the leak oil quantity which flows through within 6 s (bottom left scale of tester) and multiply by ten in order to obtain the quantity per minute.

5 Repeat test by turning steering to the right.

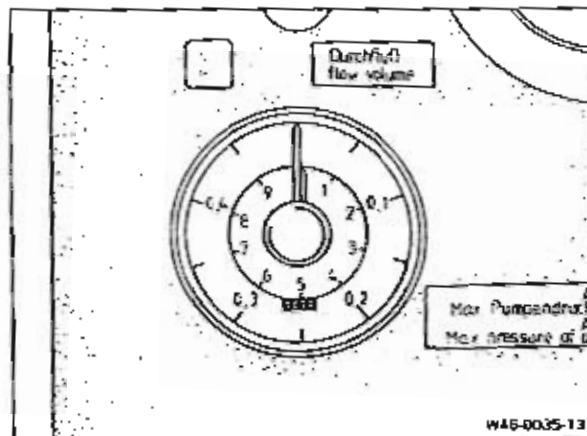

Maximum permissible leak oil quantity 3.5 l/min in each case when turning to left or to right.

If the leak oil quantity is excessive (greater than 3.5 l/min) the causes may be one of the following:

- Damaged or worn high pressure seals of working piston, steering worm and pitman arm shaft.
- Scoring in the cylinder bore of the steering housing. Control edges not closing properly as a result of foreign bodies, damage or wear.

The steering must be removed and replaced in order to eliminate this operating problem.

Scope of work

- 1 Check that steering knuckle and steering joints operate freely.
- 2 Check tyre inflation pressure and adjust to correct pressure if necessary.
- 3 Adjust wheel lock, allowing for clearance of tyres.
- 4 Move vehicle with the front wheels onto rotating plates with degrees scale.
- 5 When checking toe-in, move the front wheels into the exact straightahead position and check whether the steering gear is in the center position.
- 6 Move steering into center position by halving the total number of turns of the steering wheel from lock to lock.

Note:

As a check, the markings (arrows) on the face of the steering worm and on the bearing cover must be exactly aligned.

If any variation is found:

- Detach drag link at steering arm of front axle.
- As a check, the markings on the face of the steering worm (remove universal joint if necessary) must be aligned with the mark on the bearing cover.

- 7 Move front wheels into exact straightahead position. Adjust the length of the drag link so that it can be inserted in the steering arm without altering the straightahead position of the front wheels and the center position of the steering. Tighten castle nut and secure.

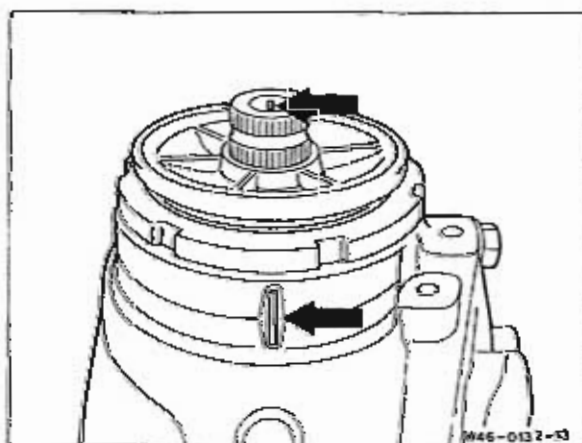

46.7-040 Adjusting pitman arm shaft

Scope of work

- 1 Raise vehicle at the front axle.
- 2 Detach drag link on one side.
- 3 Move steering into center position. Slacken lock nut (9) of the adjusting bolt (17). Tighten adjusting bolt (17) to 20 Nm to the right and then slacken 180° again to the left.
- 4 Lock hexagon nut (9) while holding adjusting bolt tight (17).
- 5 Install drag link.

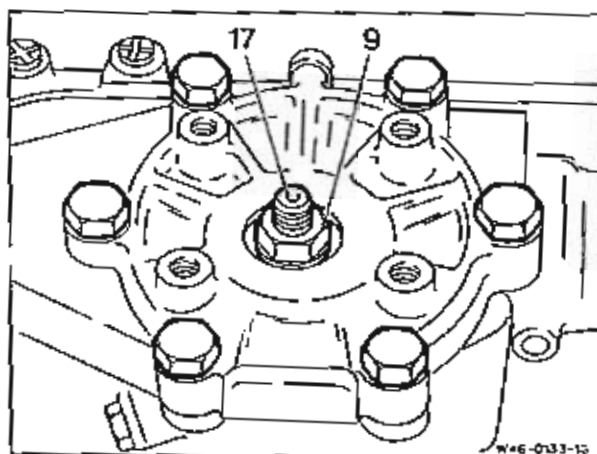

Scope of work

- 1 Raise vehicle at the front axle until the wheels are free of the ground.
- 2 Detach drag link.
- 3 Pour oil into the reservoir.

Note:

Use approved service products according to Sheet No. 236.2 / 3 / 6 / 7 of the Service Product Specifications.

- 4 Turn steering twice fully from left to right and back again.

- 5 Top up oil level.

- 6 Run engine at idle speed and turn steering several times briskly from lock to lock. This automatically bleeds the steering system.

Note:

Allow engine to run until no more air bubbles appear in the oil reservoir. With the engine running, the oil level must extend up to the top marking of the dipstick (10) or transparent oil reservoir.

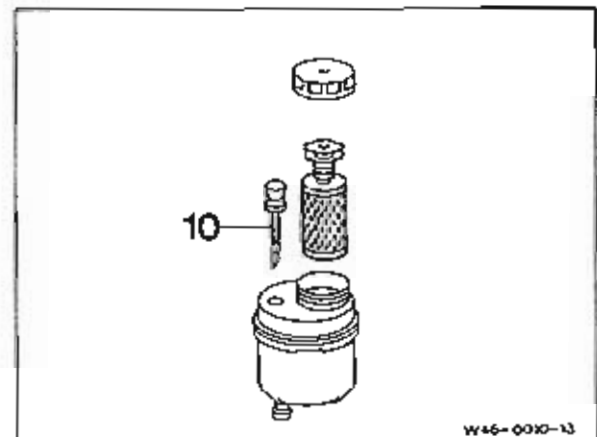

46.7-050 Checking and adjusting limit valves

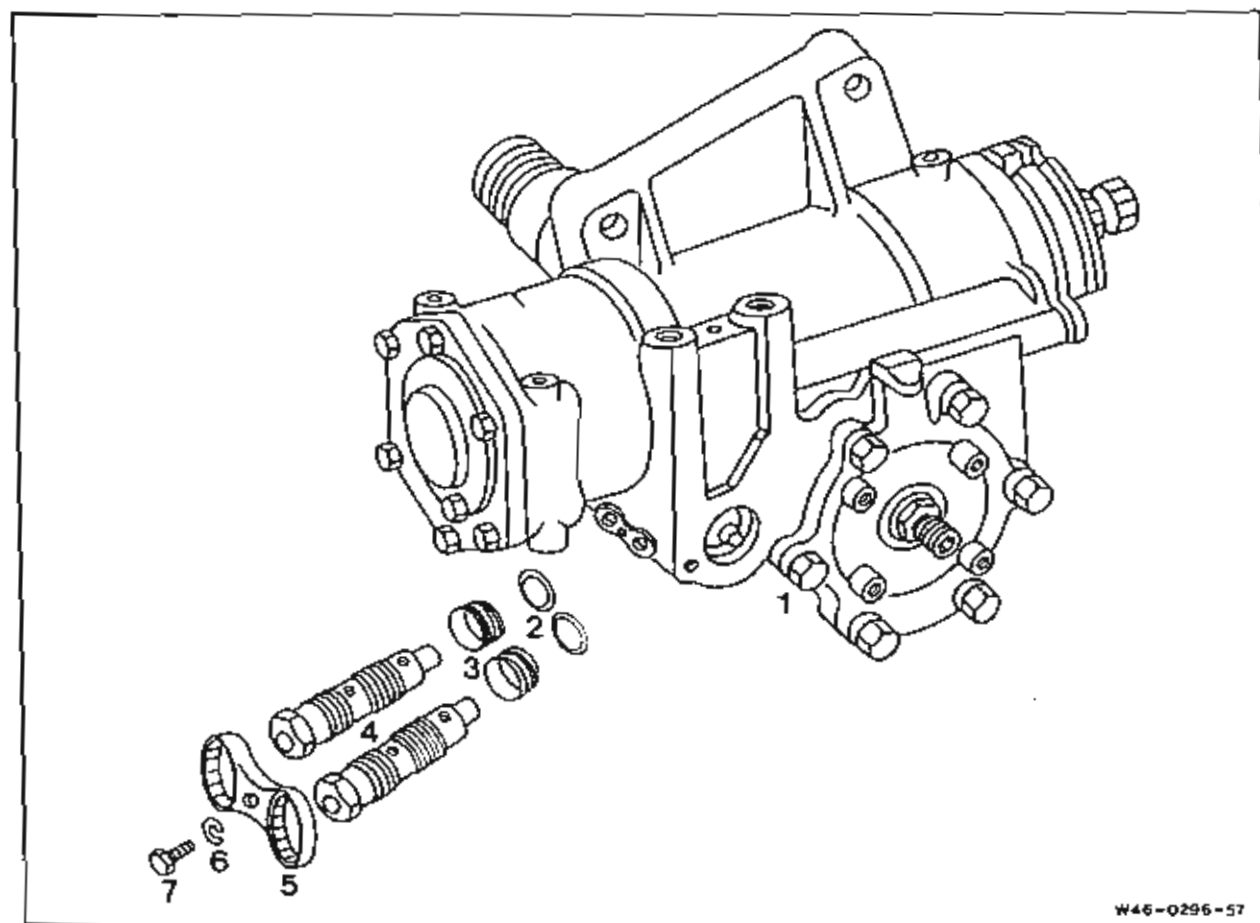

- 1 Steering
- 2 O-ring
- 3 Seal
- 4 Limit valves
- 5 Locking ring
- 6 Spring lock washer
- 7 Hexagon bolt M6 x 12 10 Nm

Special tool

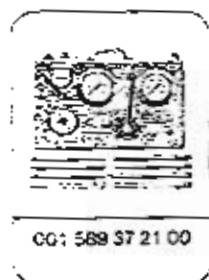

Checking

- 1 Remove locking ring (5), unscrew limit valves (4).
- 2 Press tappets (arrows) into the limit valves by hand (in direction of arrow). Spring pressure must exist. If the tappet can no longer be operated by hand, renew limit valves.
- 3 Screw in limit valves and adjust.

Adjusting limit valves

Note:

The adjusting range of the steering limiter extends from the state where the limit valves are screwed in fully to the point where they are unscrewed out the way approx. 2 turns.

CAUTION!

For safety reasons, the limit valves must not be slackened more than 2 1/2 turns when the engine is running - valves are pressurized.

- 1 Adjust steering center position and wheel lock beforehand.
- 2 Connect tester (see 46.7-020).
- 3 Perform pressure test with the tester (see 46.7-025).
- 4 Raise vehicle at both front axes until the wheels are clear of the ground.
- 5 Run engine at approx. 800 rpm. Bleed steering system by turning steering wheel several times from lock to lock.

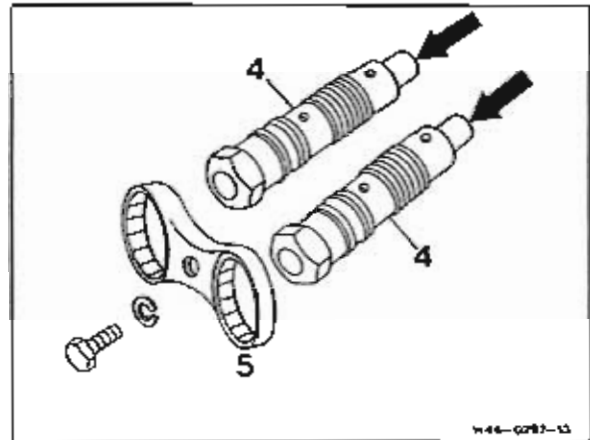

6 Unscrew hexagon bolt (7) and remove locking ring (5).

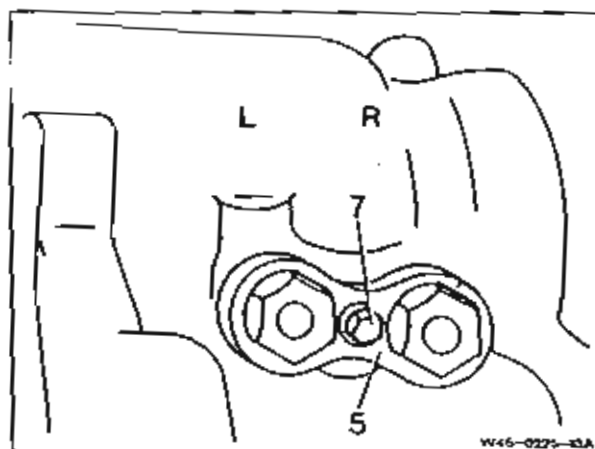

7 Screw in both limit valves (4) in the center position of the steering as far as the stop.

8 Unscrew the valve for left lock 2 1/2 turns.

Limit valves (4):

Cast marking on steering housing (arrows)

R = for right lock

L = for left lock

Check markings with cab tilted and ensure you pay attention to the markings when performing adjustment.

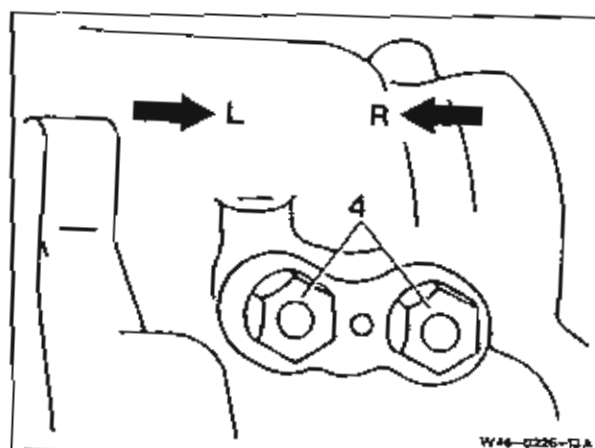

9 Adjusting at left lock

Fit torque wrench with wrench socket onto the steering wheel mounting and hold tight with a force of 30 Nm against the left steering stop for the duration of the adjustment operation.

Screw in limit valve for left lock (L) far enough to obtain a pressure of approx. 45 ± 10 bar on the high pressure gauge (0 - 250 bar).

10 Adjusting at right lock

Screw in limit valve for right lock (R) far enough for a pressure of 45 ± 10 bar to be achieved on the high pressure gauge (0 - 250 bar).

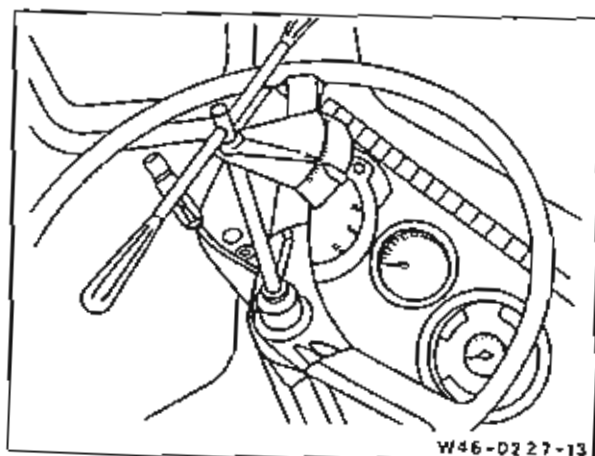

11 Re-check adjustment at left lock. The setting must be 45 ± 10 bar.

12 Fit on locking ring (5) and tighten with hexagon bolt (7) to 7 Nm.

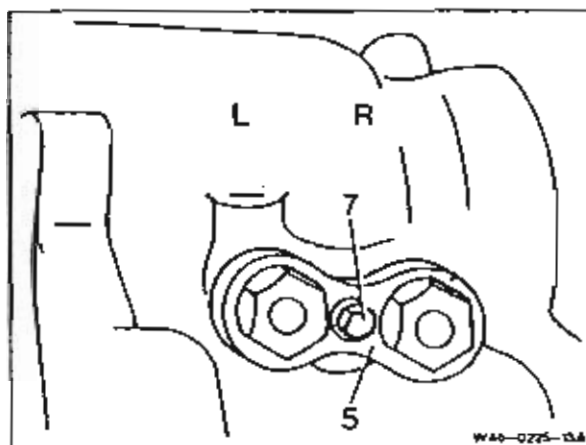

46.7-055 Removing and installing steering

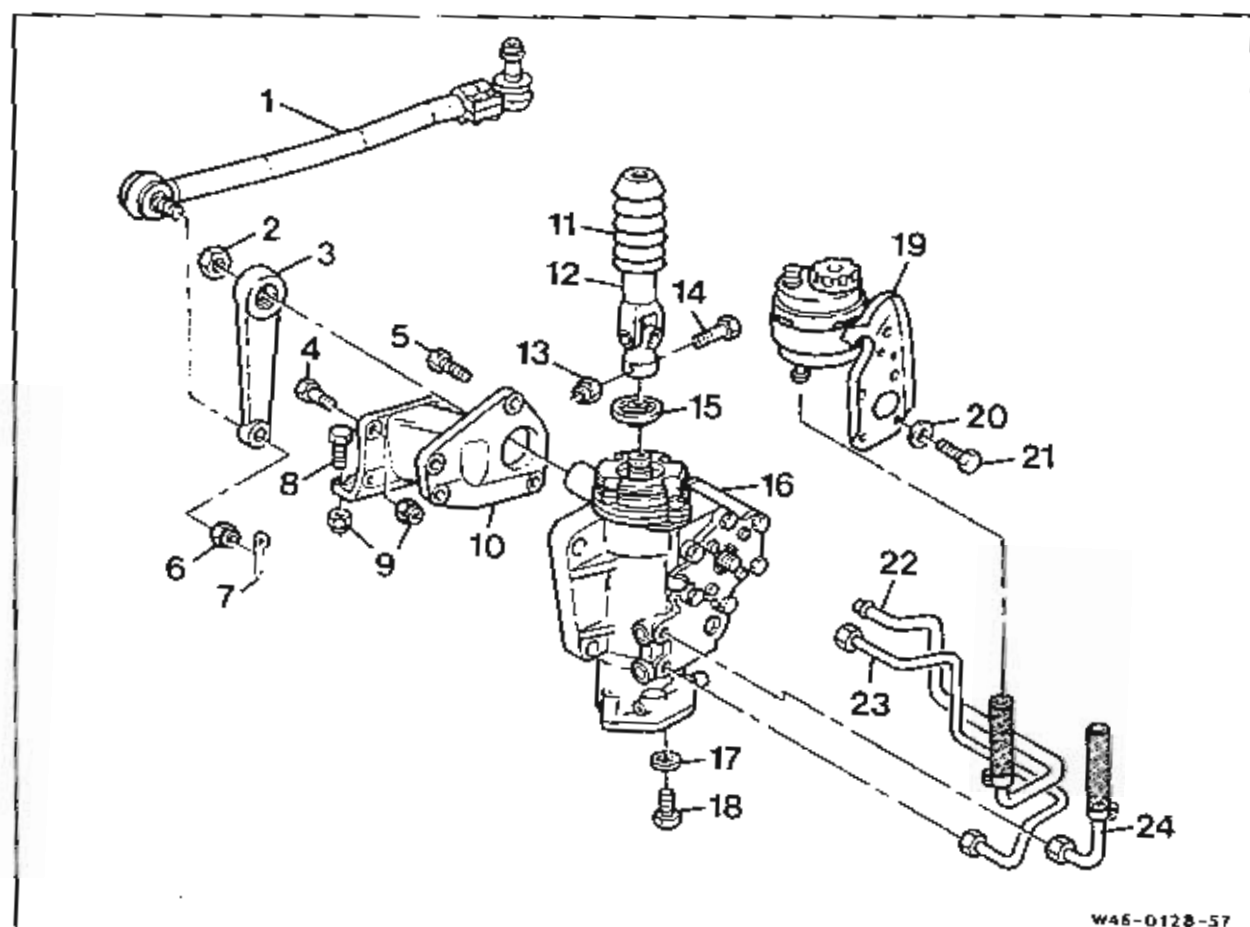

W46-0128-57

1	Drag link		
2	Self-locking nut M45×1.5	renew, 750 Nm	
3	Pitman arm		
4	Bolt M14×1.5×50	172 Nm	
	M16×1.5×50	260 Nm	
5	Bolt M16×1.5×45	237 Nm	
6	Castle nut M24×1.5	280 Nm	
7	Split pin	renew	
8	Bolt M14×1.5×55	172 Nm	
	M16×1.5×55	260 Nm	
9	Self-locking nut M14×1.5	renew, 172 Nm	
10	Steering bracket		
11	Boot		
12	Steering shaft		
13	Self-locking nut M8×1.5	renew, 34 Nm	
14	Bolt M8×42	34 Nm	
15	Washer	renew	

16	Steering	
17	Seal	renew
18	Oil drain plug M12×1.5	55 Nm
19	Bracket with oil reservoir	
20	Snap ring (4 off)	
21	Bolt M10×20 (4 off)	60 Nm
22	Oil return line	
23	Oil delivery line	60 Nm
24	Oil return line	90 Nm

Special tools

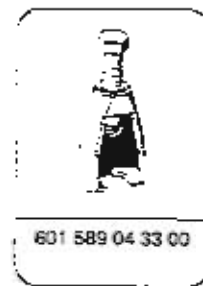
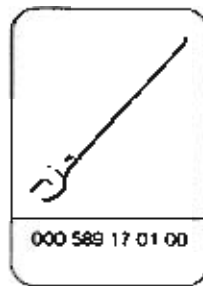
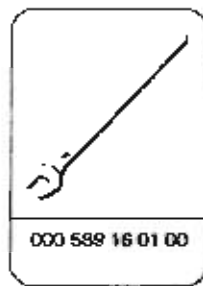

Note:

To avoid unjustified replacement of power steering systems and power steering pumps and redebiting of costs, perform the following checking and adjustment work depending on the complaint:

- 46.7 - 020 Testing power steering pump
- 46.7 - 025 Testing steering for pressure
- 46.7 - 030 Testing steering for leak oil
- 46.7 - 035 Checking and adjusting steering center position
- 46.7 - 040 Adjusting pitman arm shaft
- 46.7 - 045 Bleeding steering, checking and correcting oil level
- 46.7 - 050 Checking and adjusting limit valves

Removing steering

- 1 Tilt cab.
- 2 Drain steering oil.

Note:

If steering not fitted with oil drain plug, drain oil through hydraulic line connection.

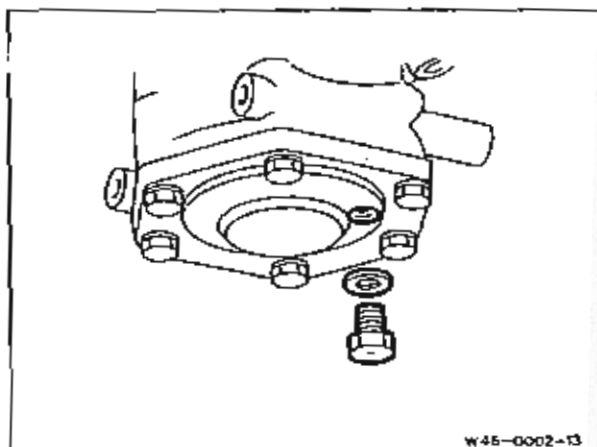

- 3 Release lock on castle nut and unscrew. Remove drag link.

Puller 601 589 04 33 00

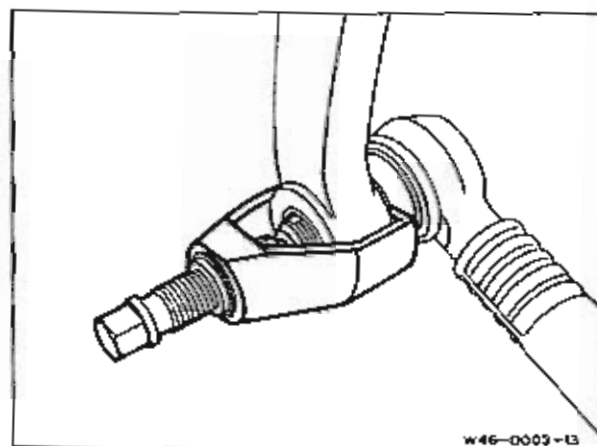

- 4 Detach lines (22, 23, 24).

Note:

Plug all openings (risk of dirt).

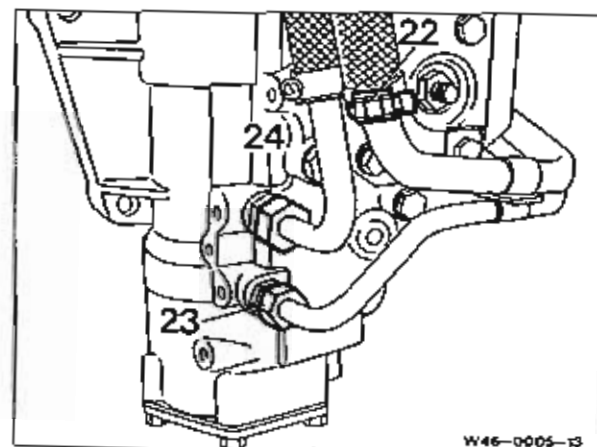

- 5 Remove bracket together with oil reservoir.

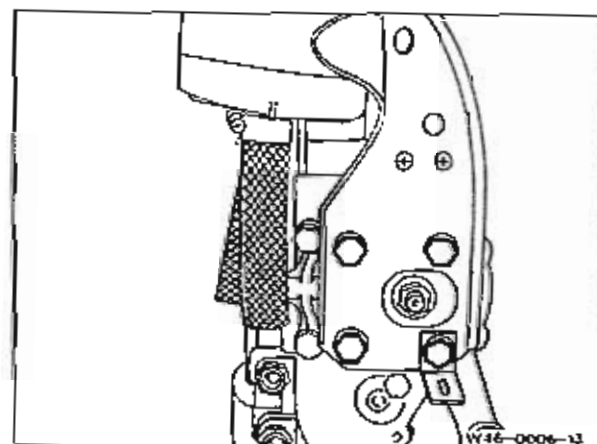

6 Push up boot, remove nut and bolt, remove universal joint (12) and cover (15).

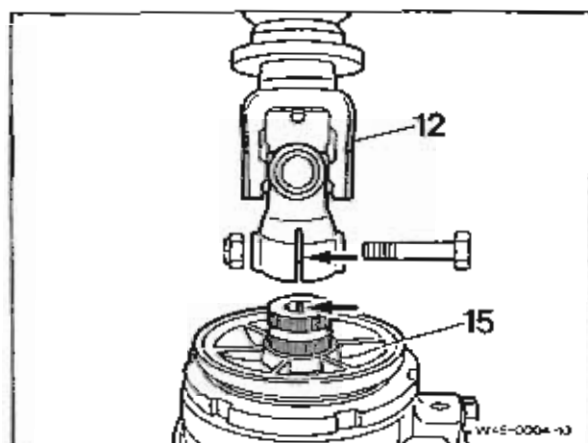

7 Remove steering bracket together with steering at frame.

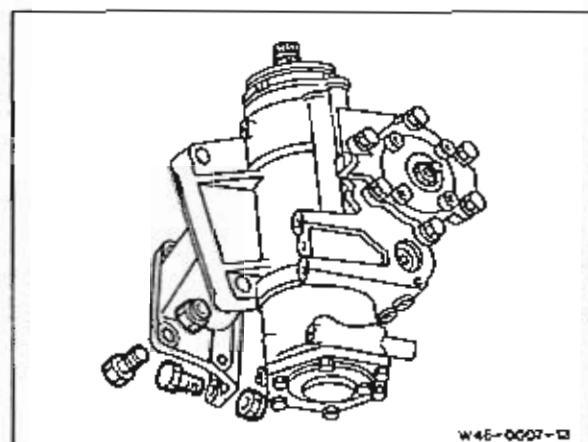

8 Remove nut at pitman arm.

Fork wrench wal 65 - 000 589 16 01 00
Fork wrench wal 70 - 000 589 17 01 00

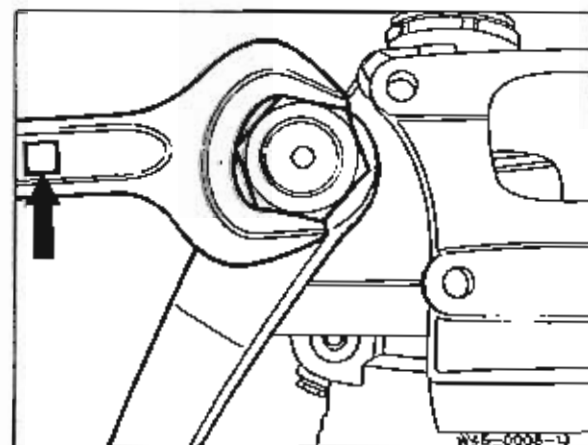

9 Remove pitman arm.

Puller 363 589 01 33 00

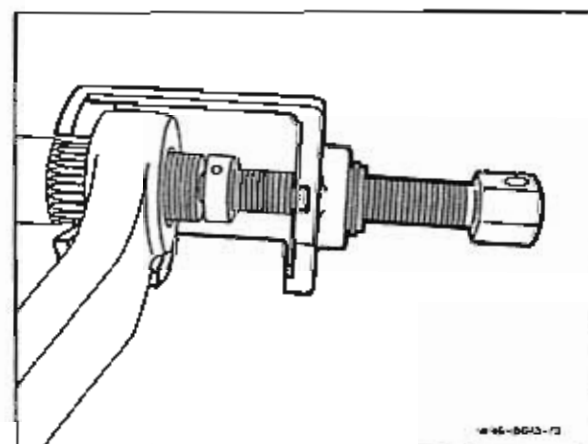

10 Remove bolts (5), take off steering bracket.

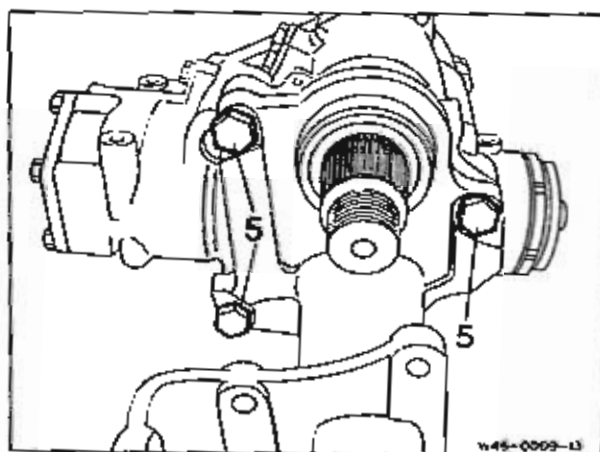

Installing steering

1 Bolt steering bracket onto steering with bolts (5) and tighten to 260 Nm.

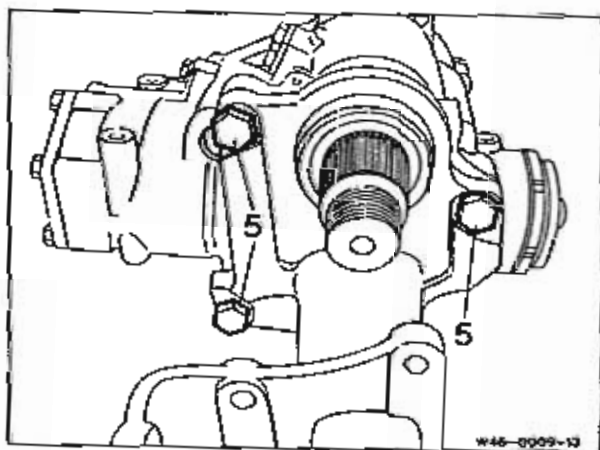

2 Fit on pitman arm.

Note:

Pay attention to markings (arrows).

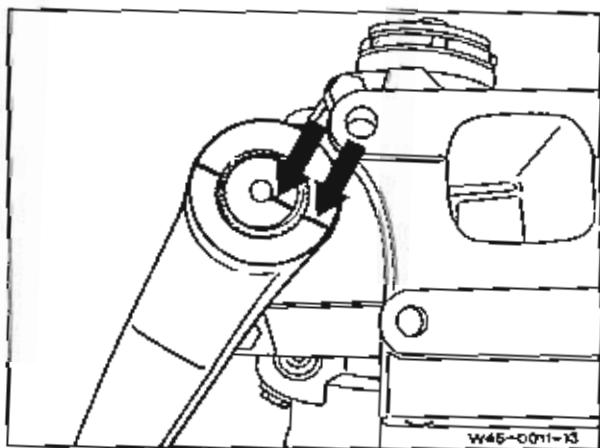

3 Attach pitman arm.

3.1 Fit on new self-locking nut and tighten at square hole (arrow) of the fork wrench to 670 Nm.

- **Note:**

This value corresponds to an actual tightening torque of 750 Nm.

- Use self-locking nut only once.

Fork wrench wal 65 - 000 589 16 01 00

Fork wrench wal 70 - 000 589 17 01 00

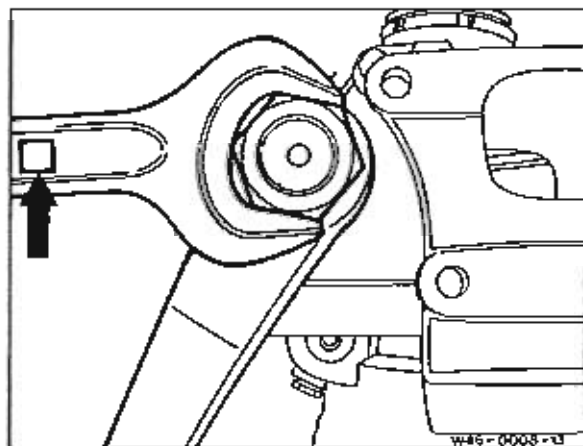

3.2 Fit on castle nut and tighten at square hole (arrow) of the fork wrench to 540 Nm.

- **Note:**

This value corresponds to an actual tightening torque of 600 Nm.

- Secure castle nut with split pin.

Fork wrench wal 70 - 000 589 17 01 00

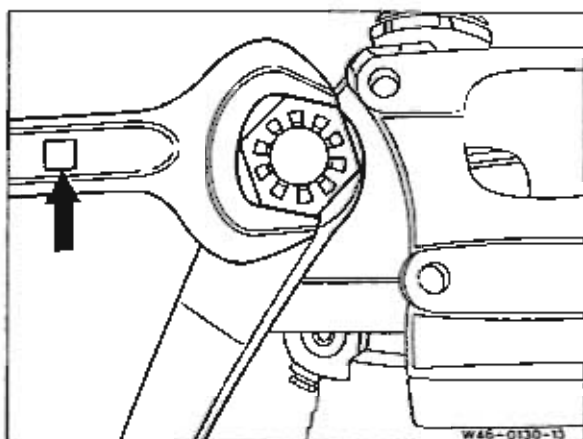

4 Attach steering bracket together with steering to frame and tighten to 260 Nm.

Note:

Use self-locking nut only once.

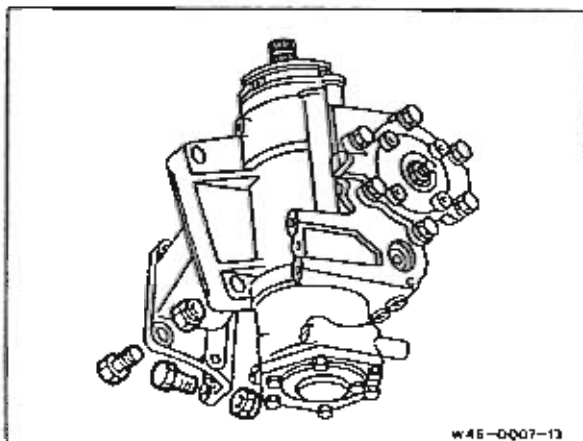

5 Attach oil reservoir with bracket to the steering and bolt tight to 60 Nm.

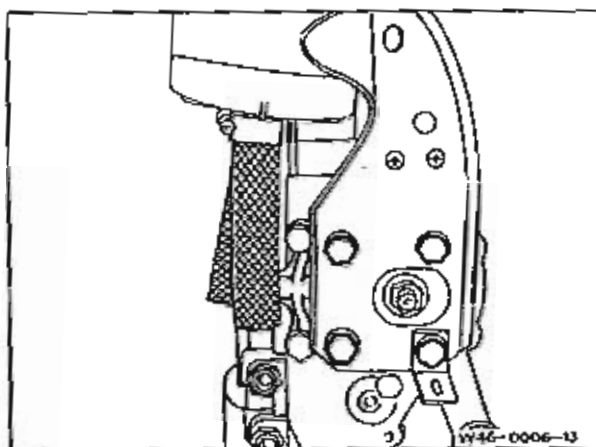

6 Attach lines. Bolt line (24) tight to the steering with 90 Nm and line (23) to 60 Nm.

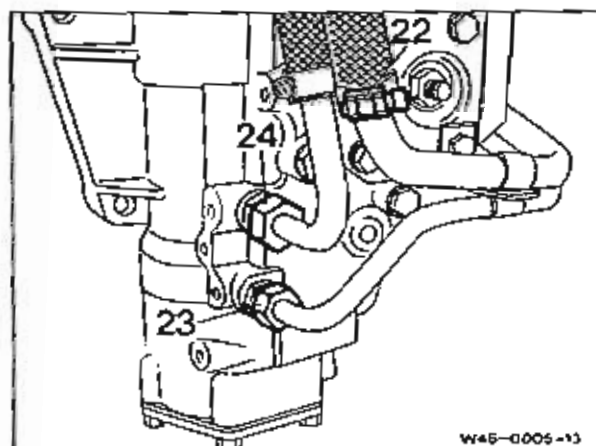

7 Fit on cover (15).

8 Install steering shaft (12) and bolt tight to 34 Nm.

Note:

When installing steering shaft, ensure that the slot (arrow) on the universal joint is aligned with the notch (arrow) on the steering worm.

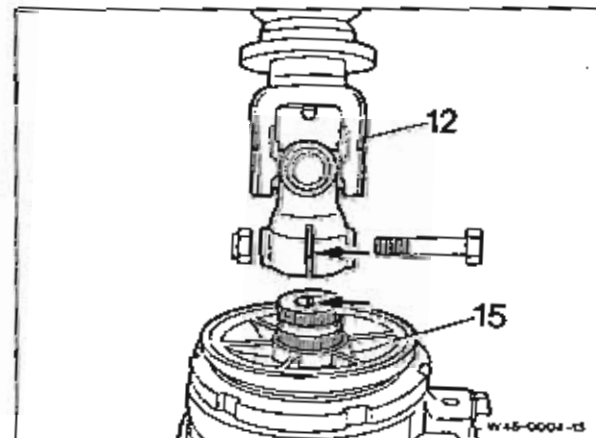

9 Move front wheels into straightahead position.

10 Check steering center position and adjust (46.7-035).

11 Attach drag link to pitman arm. Tighten castle nut to 280 Nm and secure with split pin. Tighten clamp of drag link to 70 Nm.

Note:

Adjust drag link, if necessary.

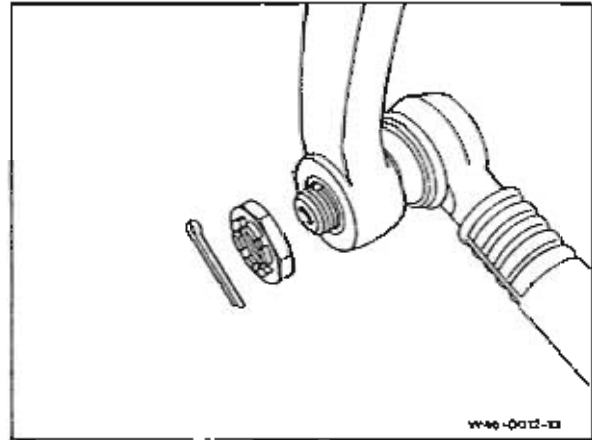

12 Screw in oil drain plug and tighten to 55 Nm.

13 Pour in oil.

14 Bleed steering (46.7-045).

15 Adjust pitman arm shaft (46.7-040).

16 Adjust limit valves (46.7-050).

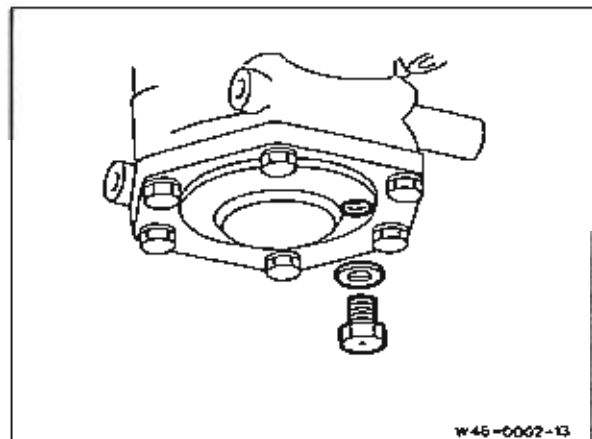

46.7-060 Renewing hydraulic lines

Special tool

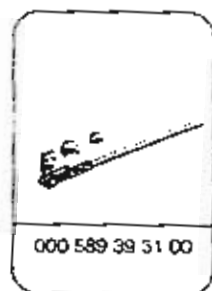

Note:

- The hydraulic lines are not all available as replacement parts.
- Missing lines must be shop-made using the removed line as a basis.
- Use the bending device Part No. 000 589 39 31 00 for bending.
- Carefully clean lines before installing.
- After installing lines, bleed steering (46.7-045).

General

1 A strict standard should be applied when checking the steering components. In cases of doubt, always renew the part concerned.

2 When repairing the steering system, always renew the Teflon seals and O-rings involved. Before examining, clean all parts thoroughly with cleaning naphtha.

3 Always renew self-locking nuts and bolts.

Steering housing and housing cover

1 Examine the running surface of the working piston for signs of scoring and wear.

2 Replace needle bearings and radial seals in the housing and cover if damaged. Examine thread of the adjusting bolt in the cover for signs of damage. Thoroughly rinse holes in the housing and cover and clean.

Steering nut and steering worm

1 If the ball tracks are worn, renew both parts together (steering worm, nut, balls and axial angular-contact ball bearing are supplied only as a complete assembly). Steering worm, nut and balls are combined in the matching process.

2 Examine axial bearings of steering nut and steering worm (in bearing cover) for signs of wear and renew if damaged.

Working piston

1 Examine serrations of working piston for signs of cracks, indentations and outer diameter for scoring.

Pitman arm shaft

1 Examine pitman arm shaft for twisting and cracks. Examine teeth for indentations and wear.

2 Examine bearing points of pitman arm shaft for signs of wear and indentations.

3 Examine seal of the radial seal for rust areas and wear.

Bearing inserts

1 Examine radial seal in outer bearing insert for signs of wear; renew, if necessary.

2 Examine seal of the axial bearings.

3 Thoroughly rinse holes in the inner bearing insert and clean.

Valve spool

1 Thoroughly clean all control parts, moisten with oil and check that they operate smoothly. Examine control edges for signs of wear.

2 If the valve spool has to be renewed, this is only possible together with the steering housing. Both parts are selected in the matching process.

46.7-070 Removing and installing pitman arm shaft

Preceding work:
Steering removed (46.7-055)

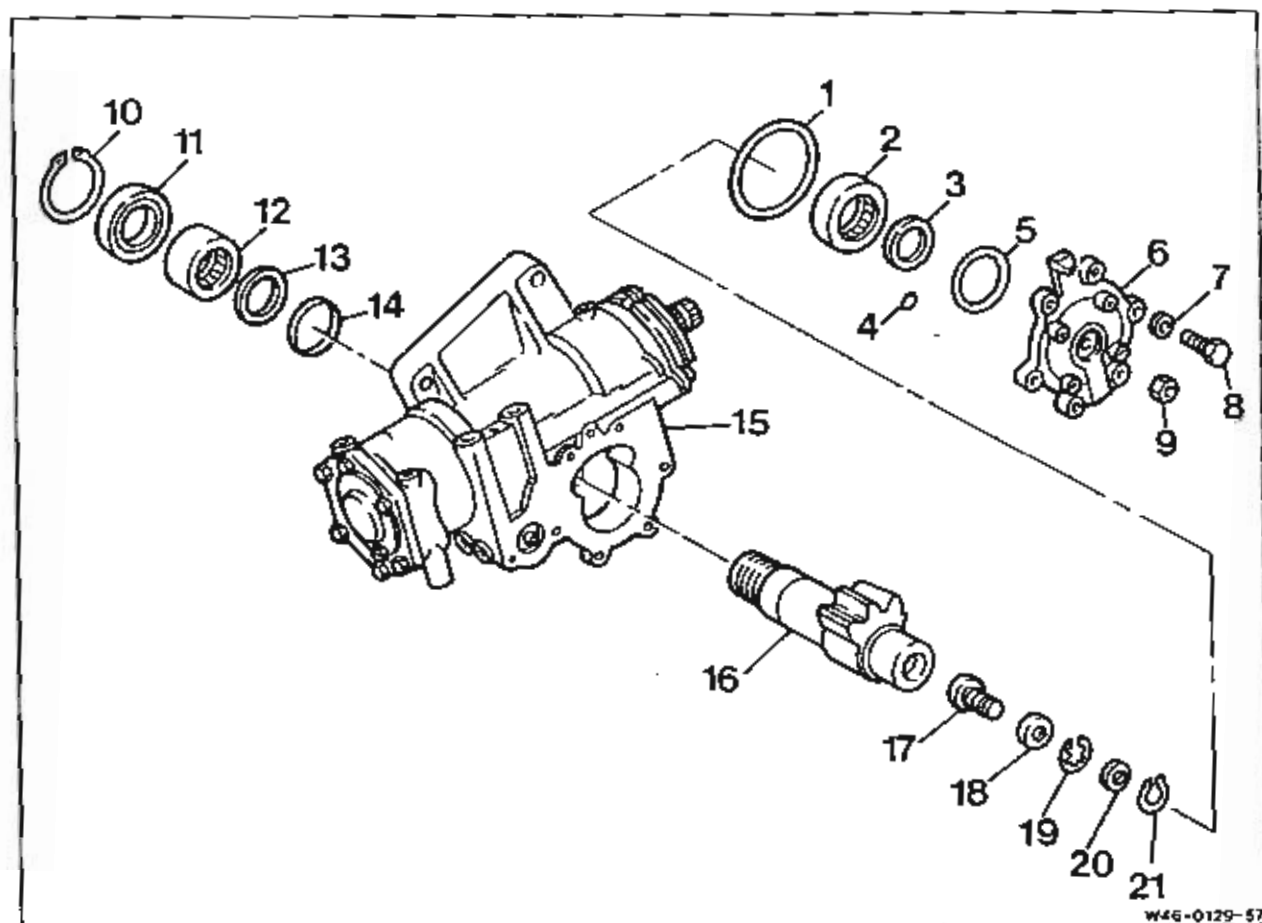

W46-0129-57

1 O-ring	renew
2 Needle bearing	Internal extractor 000 589 30 33 00 Counter-support 000 589 34 33 00 Drift 352 589 04 15 00
3 Teflon ring	renew
4 O-ring	renew
5 O-ring	renew
6 Housing cover	
7 Spring lock washer	
8 Bolt M12×1.5×38	LS 7F 120 – 125 Nm
M10×30	LS 5F 64 – 68 Nm
9 Hexagon nut M14×1.5	80 – 85 Nm
10 Locking ring	
11 Shaft seal	renew, grease
12 Needle bearing	Internal extractor 000 589 30 33 00 Counter-support 000 589 34 33 00 Drift 352 589 04 15 00

- 13 Teflon ring *renew*
- 14 O-ring *renew*
- 15 Steering housing Assembly device 315 589 02 31 00
- 16 Pitman arm shaft
- 17 Adjusting screw M 14 x 1.5 Dial gauge holder 363 589 02 21 00
Dial gauge 001 589 53 21 00
- 18 Thrust washer
- 19 Locking ring
- 20 Thrust washer
- 21 Locking ring

Special tools

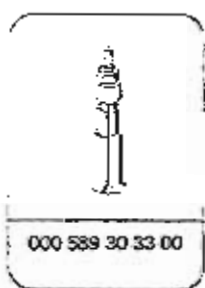
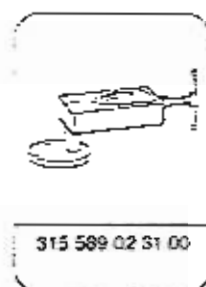
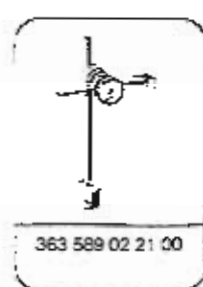
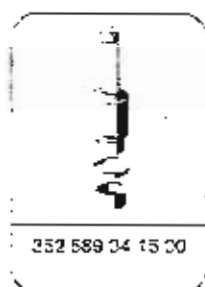

A Removing and disassembling pitman arm shaft

- 1 Clamp steering in assembly device.

Assembly device 315 589 02 31 00

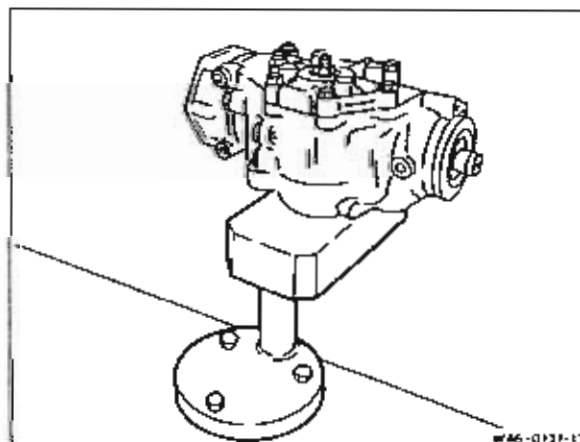

W46-0127-13

2 Move working piston into center position. The center position is reached by halving the total number of turns of the steering worm.

3 Check whether the steering gear is in center position (markings on steering worm and steering housing aligned, arrows).

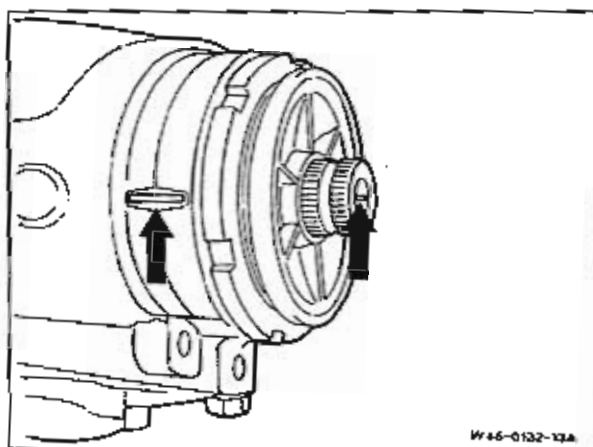

4 Unscrew hexagon bolts (8).

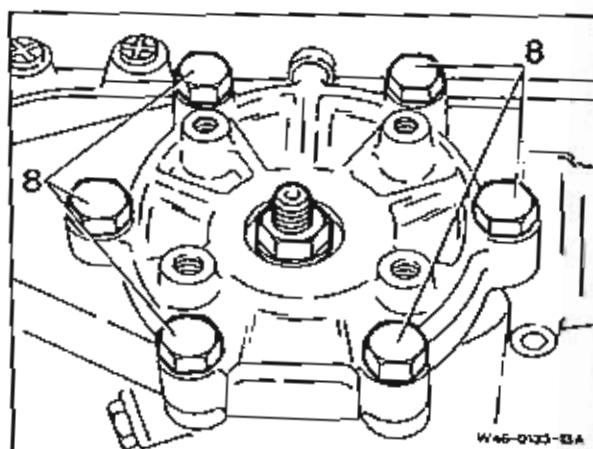

5 Remove pitman arm shaft together with housing cover from the steering housing by applying light blows to the end of the pitman arm shaft.

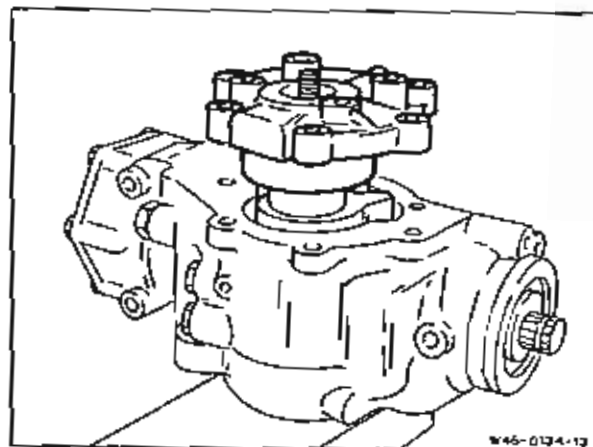

6 Unscrew lock nut (9) of the adjusting screw (17), holding the adjusting screw tight (17) with Allen key.

7 Screw in adjusting screw (17) fully and take off housing cover.

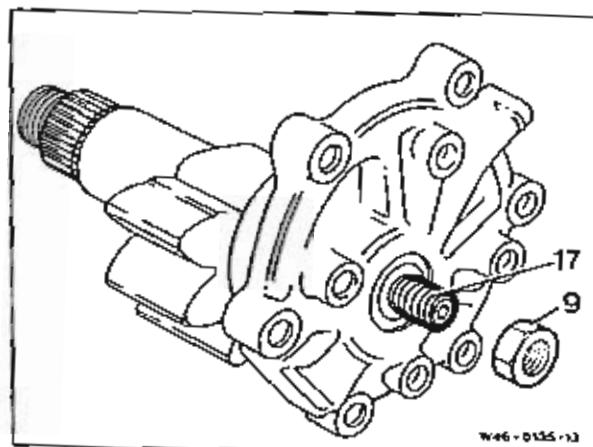

8 Remove locking ring (21) from the pitman arm shaft, take out thrust ring (20), remove locking ring (19).

9 Withdraw adjusting screw (17) together with spacer washer (18).

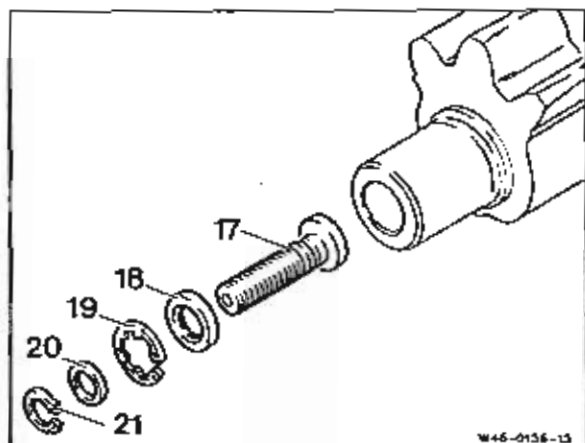

B Disassembling and assembling housing cover

Disassembly

1 Remove needle bearing (2) from the housing cover using internal extractor and counter-support.

Internal extractor 000 589 30 33 00

Counter-support 000 589 34 33 00

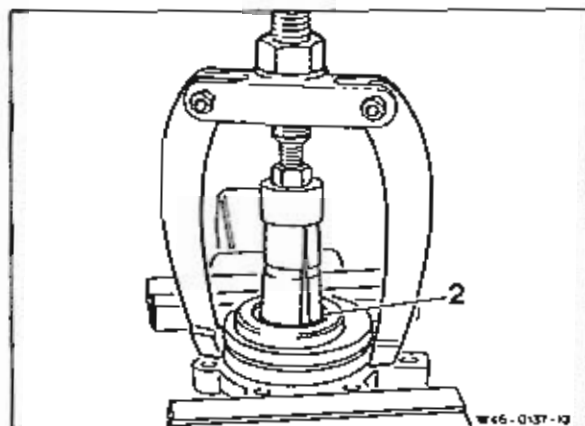

2 Take off Teflon seal (3) and O-ring below it (5) as well as the O-rings (1 and 4).

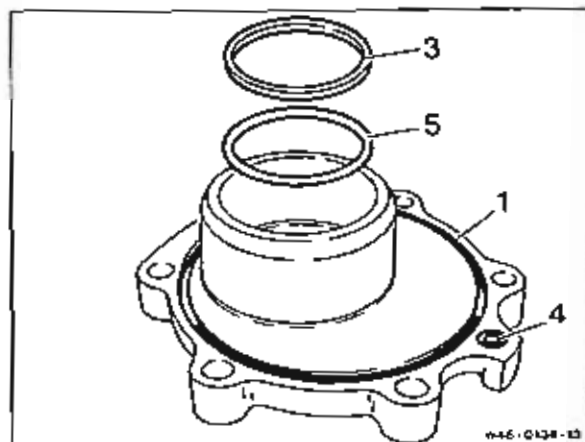

Assembly

Note:

When assembling or installing, moisten all sliding parts, particularly the bearings, with oil.

1 Insert Teflon seal (3) and O-ring below it (5) into the housing cover.

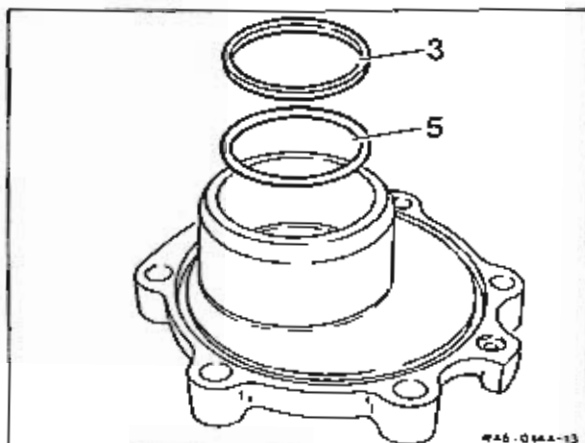

Note:

To facilitate installation, place Teflon seal into a mixture of warm water and a few drops of oil before installing, and bend in radially into the groove for inserting.

- 2 Press needle bearing (2) into the housing cover as far as it will go, using the drift.

Drift 352 589 04 15 00

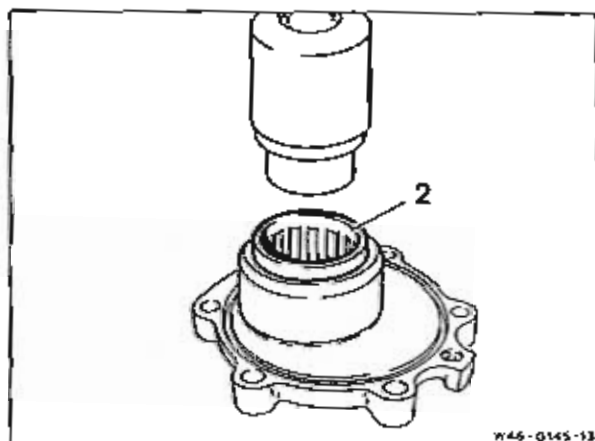

C Removing and installing pitman arm shaft bearing from steering housing

Removal

- 1 Remove locking ring and radial seal from the steering housing.

- 2 Remove needle bearing (12).

Internal extractor 000 589 30 33 00

Counter-support 000 589 34 33 00

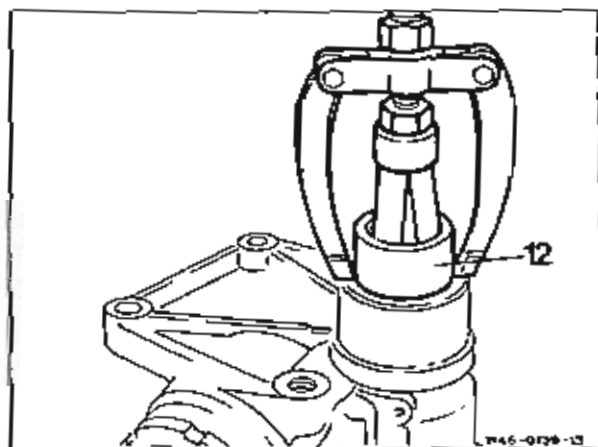

- 3 Remove Teflon seal (13) and O-ring below it (14) from the steering housing.

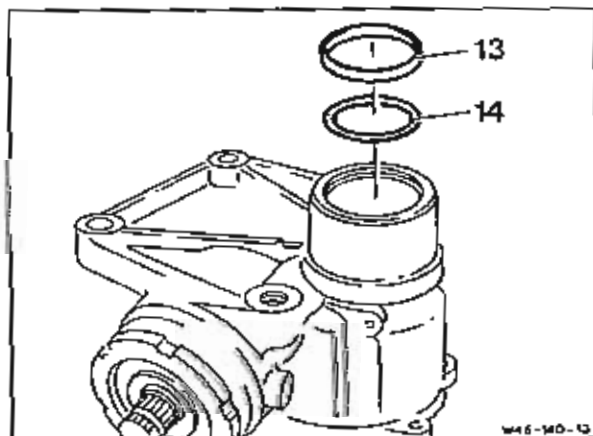

Installation

1 Install O-ring (14) and Teflon seal (13) into the steering housing.

Note I :

When assembling or installing, moisten all sliding parts, in particular the bearings, with oil.

Note II :

To facilitate installation, place the Teflon ring in a mixture of warm water and a few drops of oil before installing, and bend in slightly radially into the groove for inserting.

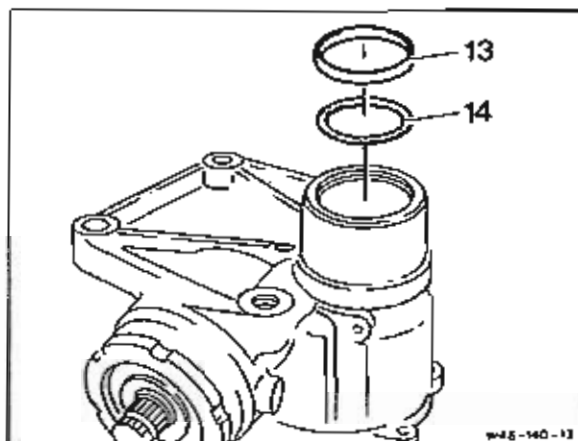

2 Press needle bearing (12) into the steering housing using the drift.

Drift 352 589 04 15 00

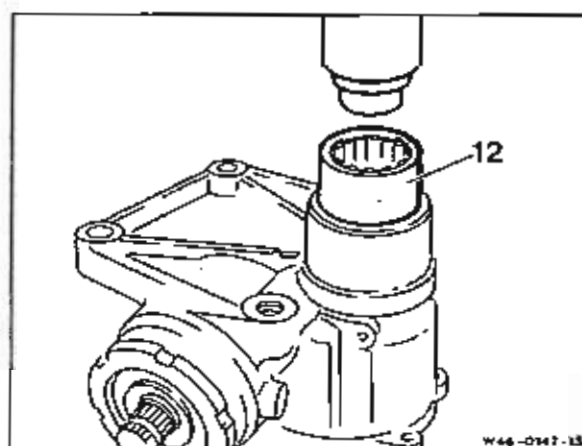

3 Install shaft seal (11) into the steering housing using the drift.

Note:

Pack space between dust lip and sealing lip with grease.

Drift 352 589 04 15 00

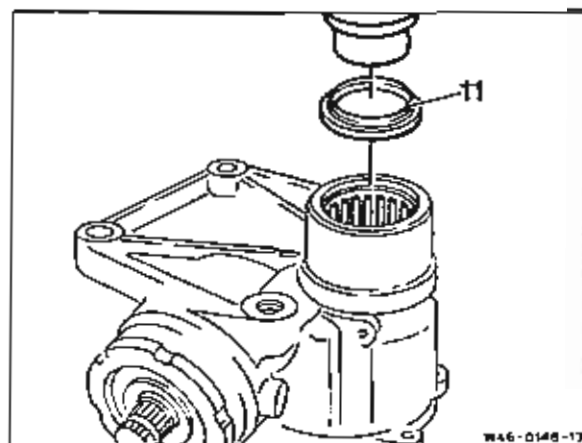

4 Install locking ring.

Arrangement of steering gear bearing

- 10 Locking ring
- 11 Shaft seal
- 12 Needle bearing
- 13 Teflon seal
- 14 O-ring
- 15 Pitman arm shaft

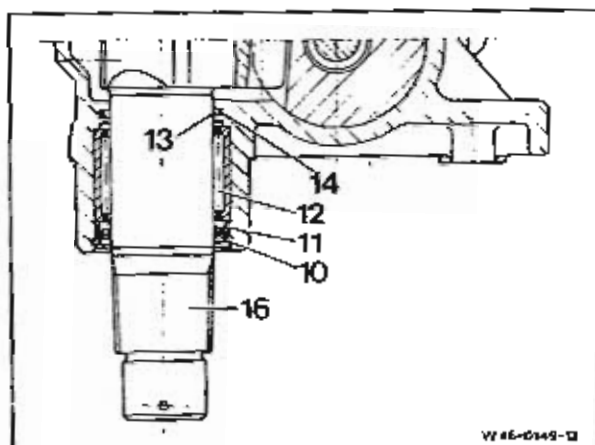

D Assembling and installing pitman arm shaft

Note:

When assembling or installing, moisten all sliding parts, in particular the bearings, with oil.

- 1 Insert adjusting screw (17) with spacer washer (18) already fitted, into the pitman arm shaft (16) and fix in place with locking ring (19).

Note:

The adjusting screw must rotate freely. End play 0.01 - 0.08 mm.

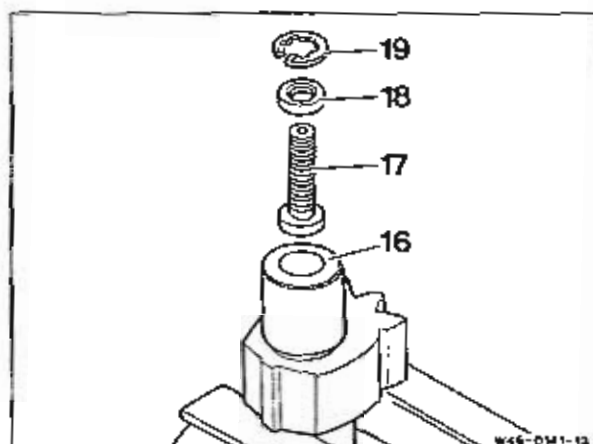

- 2 Place dial gauge onto the face end of the adjusting screw (17) (arrow). Determine end play.

End play 0.03 - 0.08 mm.

Dial gauge holder 363 589 02 21 00

Dial gauge 001 589 53 21 00

Note:

If the specified end play is not achieved, remove locking ring (19) and take out adjusting screw (17) together with spacer washer (18). Select suitable size of spacer washer and replace. Repeat measurement.

(Spacer washers are available in thicknesses from 2.4 to 3.0 mm in graduations of 1/10).

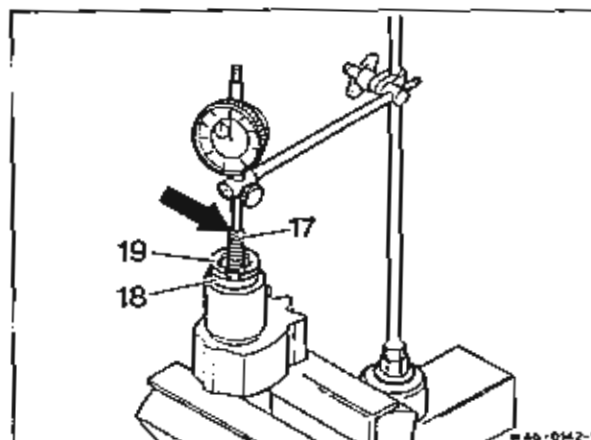

3 Fit on thrust ring (20) and install locking ring (21) on the adjusting screw (17).

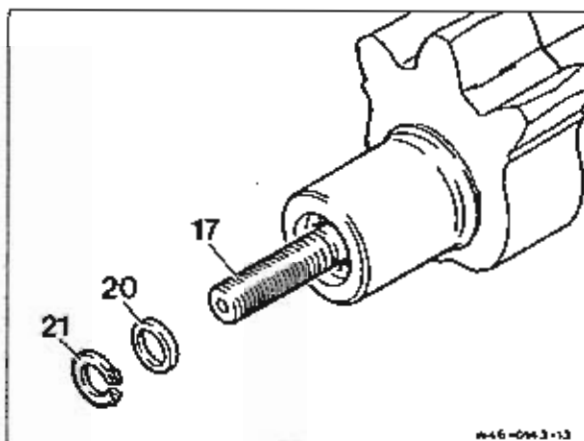

4 Insert pitman arm shaft into housing cover and unscrew adjusting screw (17) fully.

5 Fit on hexagon nut (9) but do not tighten.

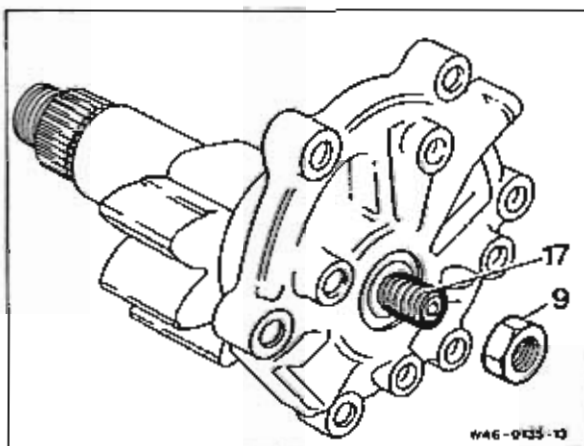

6 Insert O-rings (1 and 4) into the housing cover.

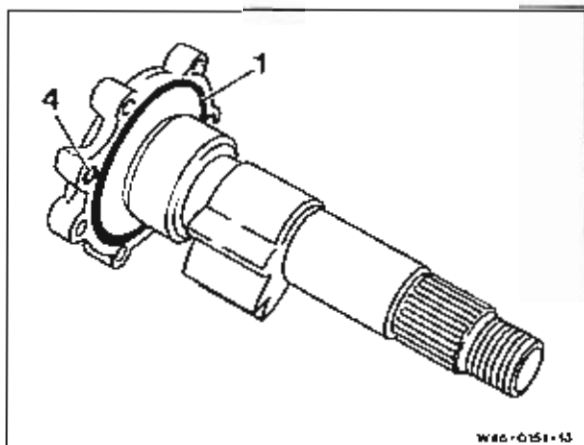

Arrangement of pitman arm shaft with housing cover

- 1 O-ring
- 2 Needle bearing
- 3 Teflon ring
- 5 O-ring
- 6 Housing cover
- 9 Lock nut
- 16 Pitman arm shaft
- 17 Adjusting screw
- 18 Thrust washer
- 19 Locking ring
- 20 Thrust washer
- 21 Locking ring

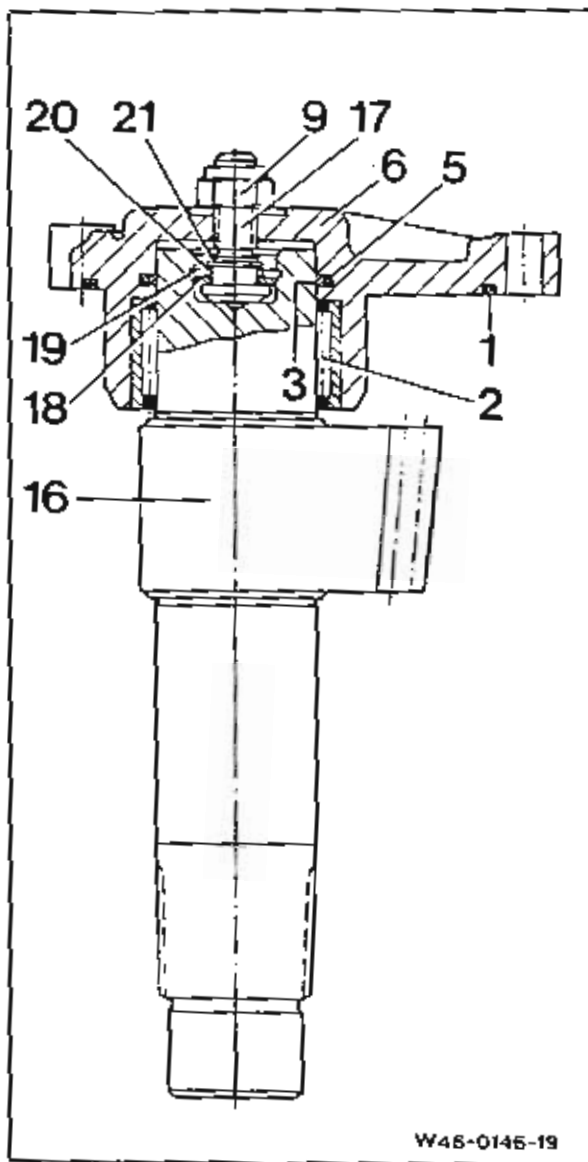

7 Move working piston into center position. The center tooth gap (arrow) must be positioned in the middle of the housing bore for the pitman arm shaft bearing.

Note:

As a check, the marking on the steering housing and on the face of the steering worm must be aligned.

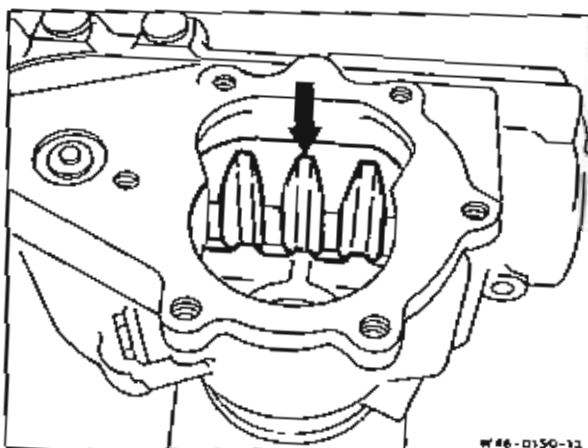

8 Carefully insert pitman arm shaft into the teeth of the working piston; if necessary, knock onto the adjusting screw by light blows with a soft hammer. Avoid damaging the radial seal or the Teflon ring.

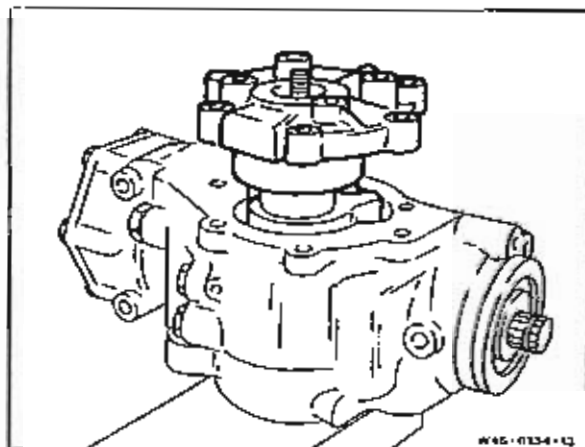

9 Screw in bolts (8) with spring lock washer.

10 Adjust pitman arm shaft (46.7-040).

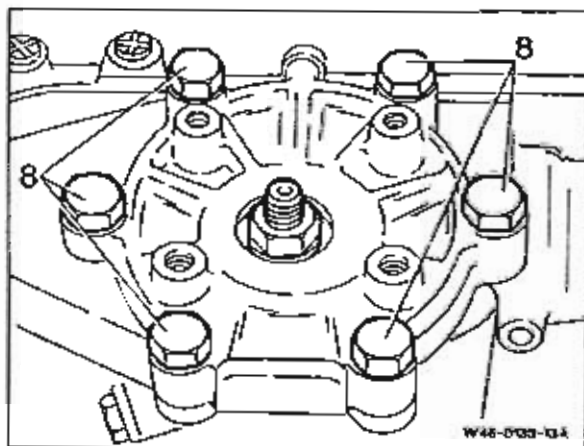

46.7-075 Removing, disassembling and assembling steering worm and working piston

Preceding work:

Pitman arm shaft removed (46.7-070)

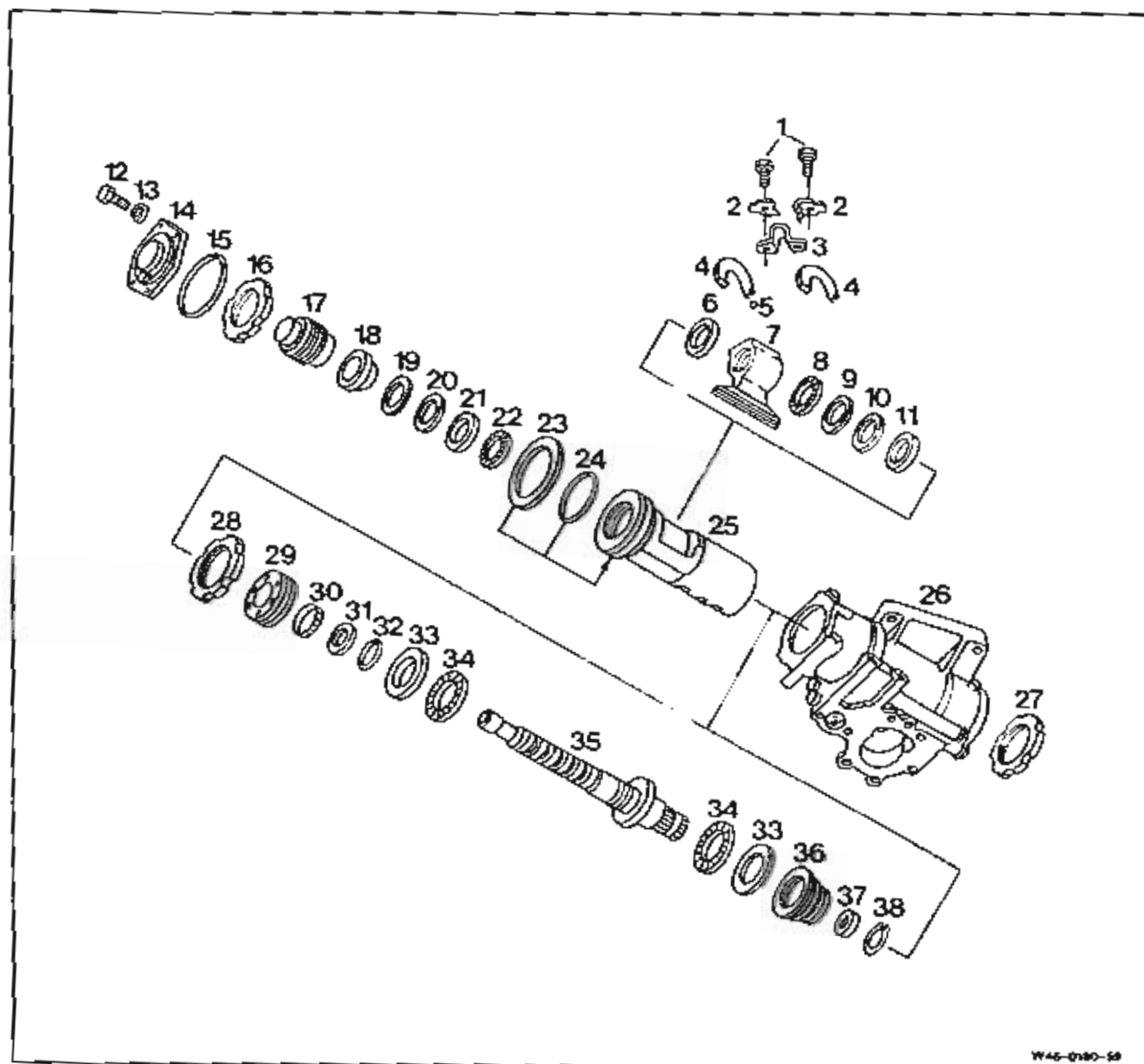

- | | |
|-----------------------------|--|
| 1 Bolt M 6×15 | 10 Nm |
| 2 Tab washer | |
| 3 Fastening clip | |
| 4 Ball guide half | |
| 5 Ball | 28 off |
| 6 Bearing race | |
| 7 Steering nut | Test device 363 589 01 21 00
Torque wrench 001 589 80 21 00 |
| 8 Axial roller bearing | |
| 9 Axial washer | |
| 10 Belleville spring washer | |
| 11 Belleville spring washer | |

12 Bolts M 10×30 (6 off)	64 – 68 Nm
13 Spring lock washer	
14 Housing cover	
15 O-ring	renew
16 Slotted nut M 72×1.5	270 Nm Pronged wrench 352 589 02 07 00
17 Screw cover	
18 Spherical washer	
19 Belleville spring washer	
20 Belleville spring washer	
21 Bearing race	
22 Axial ball bearing	
23 Teflon seal	renew
24 O-ring	renew
25 Working piston	Assembly device 352 589 00 31 00
26 Steering housing	Assembly device 315 589 02 31 00
27 Slotted nut M 83×1.5	450 – 500 Nm, Pronged wrench 352 589 01 07 00 Wrench socket 385 589 01 03 00
28 Slotted nut M 72×1.5	230 Nm Pronged wrench 352 589 02 07 00
29 Inner bearing insert	Adjusting wrench 387 589 00 07 00 Handwheel 352 589 08 63 00 Torque wrench 001 589 80 21 00
30 Needle bearing	Internal extractor 000 589 30 33 00 Counter-support 000 589 34 33 00
31 Teflon seal	renew
32 O-ring	renew
33 Spherical washer	
34 Axial roller bearing	
35 Steering worm	Retaining device 387 589 00 31 00 Assembly sleeve 352 589 01 61 00 Handwheel 352 589 08 63 00 Torque wrench 001 589 80 21 00
36 Outer bearing insert	
37 Radial seal	renew, pack seating lips with grease Drift 360 589 00 15 00 Assembly sleeve 352 589 01 61 00
38 Locking ring	

Adjustment data	Ncm
Friction torque of recirculating ball assy.	70
Friction torque of steering nut in working piston	25
Friction torque of steering worm in Teflon seal of inner bearing insert	35 - 45
Friction torque of steering worm in radial seal of outer bearing insert	15 - 20
Total friction torque of steering worm bearing with Teflon and radial seal plus 15 Ncm bearing friction torque	75 - 80

Special tools

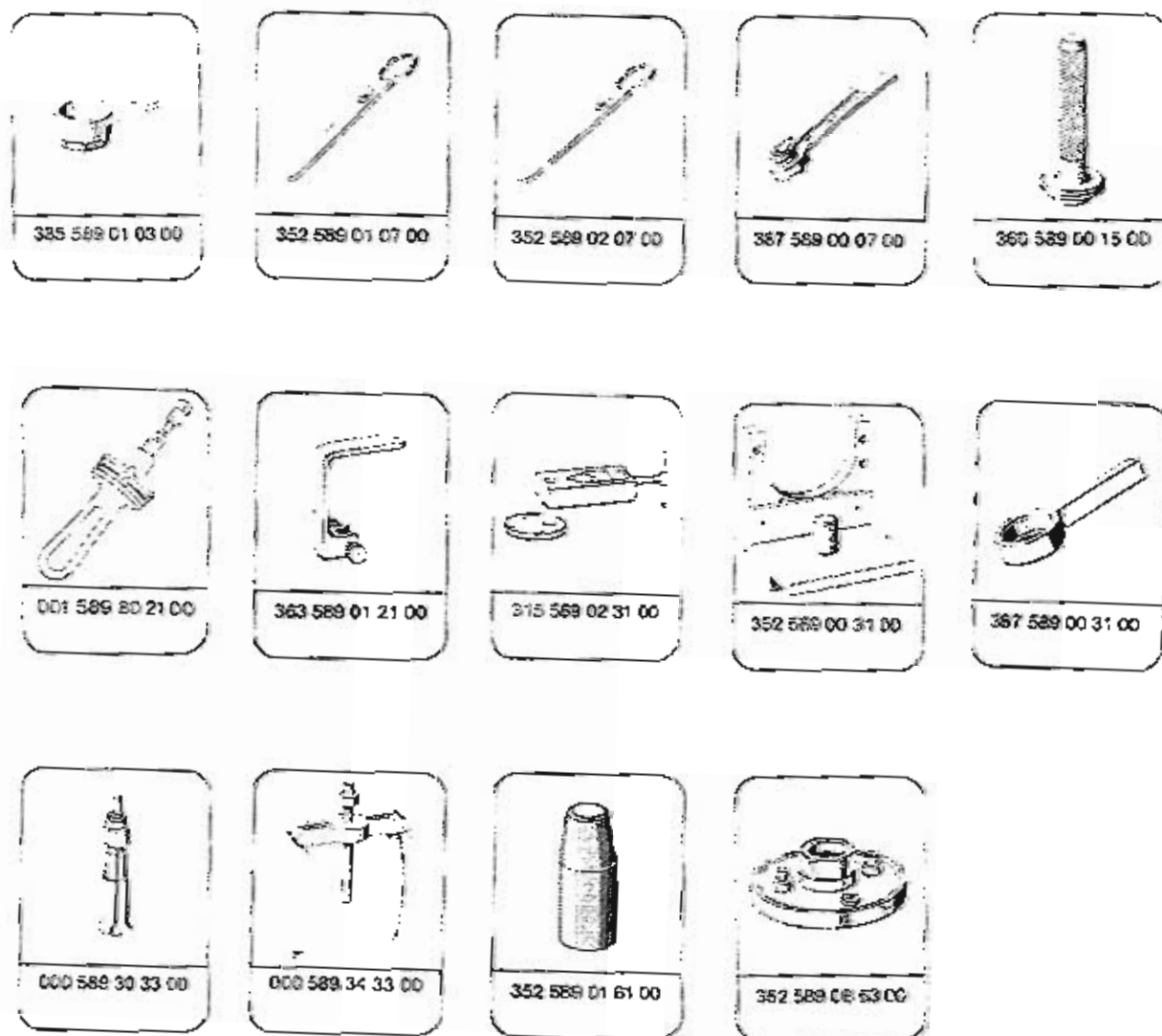

A Removing working piston

1 Clamp steering housing (26) into the assembly device. Detach housing cover (14) from the steering housing and take off O-ring (15).

Assembly device 315 589 02 31 00

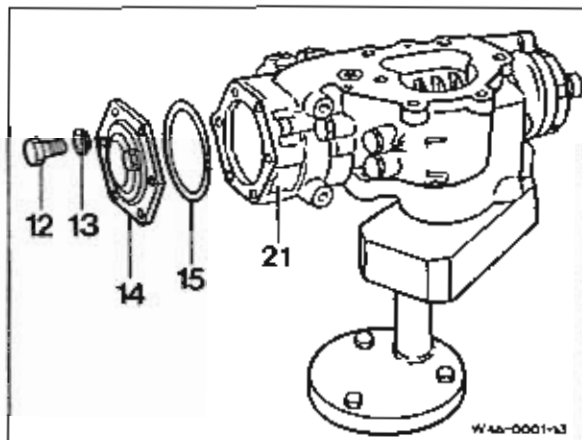

2 Unscrew slotted nut (27) from outer bearing insert (36) using pronged wrench and wrench socket.

Pronged wrench 352 589 01 07 00

Wrench socket 385 589 01 03 00

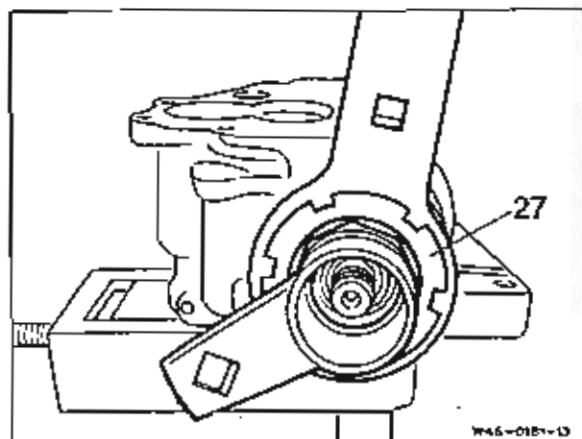

3 Knock working piston (25) together with steering worm out of the steering housing (26) using a soft hammer.

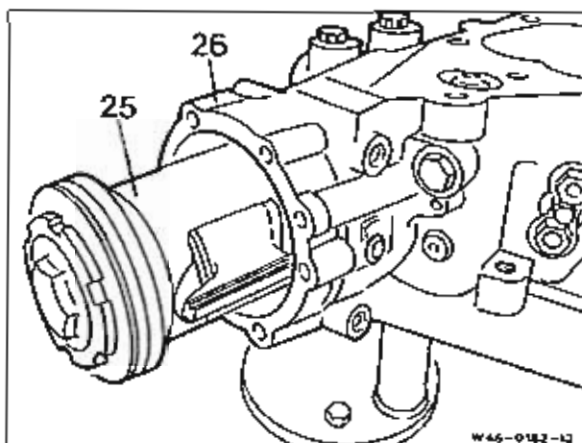

B Disassembling and assembling steering worm bearing

Disassembly

1 Unscrew steering worm (3) from the working piston (balls are then in the piston). Remove the balls in the piston (28 balls) and store in a safe place.

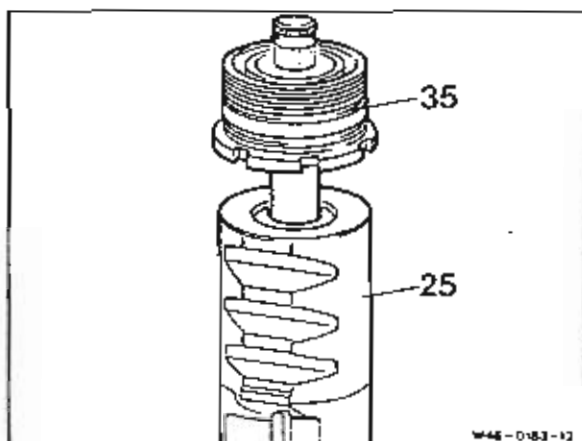

2 Insert steering worm (35) into the retaining device.

Retaining device 387 589 00 31 00

3 Slacken slotted nut (28) with pronged wrench.

Pronged wrench 352 589 02 07 00

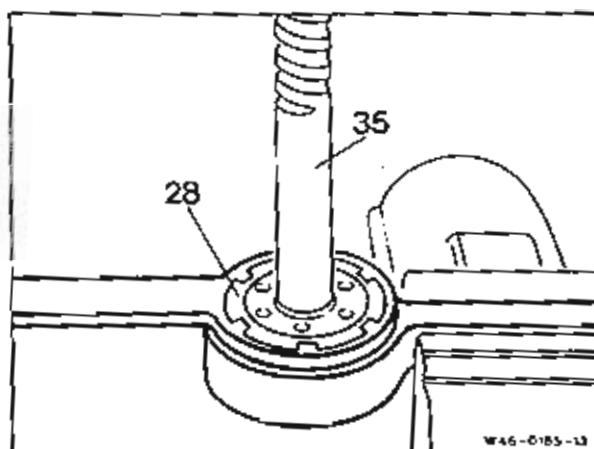

4 Detach inner bearing insert from the outer bearing insert with adjusting wrench. Remove adjusting wrench.

Adjusting wrench 387 589 00 07 00

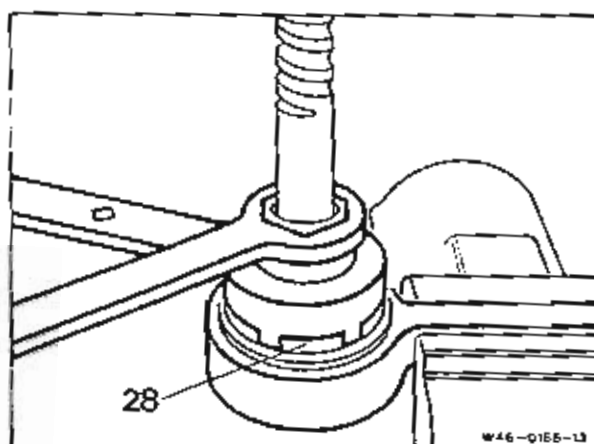

5 Unscrew slotted nut (28) and inner bearing insert (29).

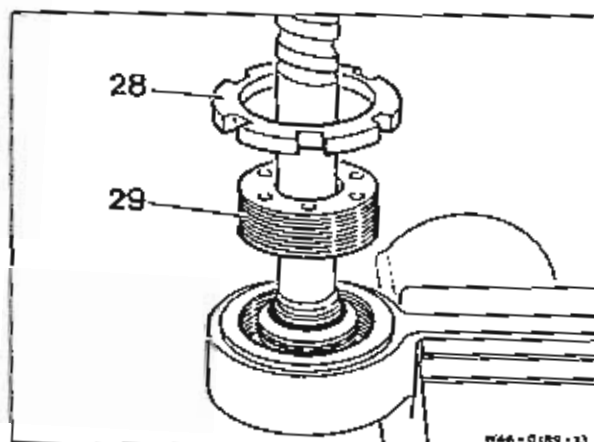

6 Take outer bearing insert (36) off the steering worm (35).

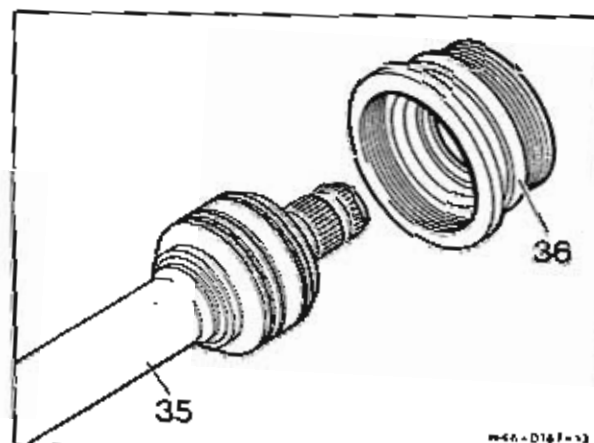

7 Take O-ring (32), Teflon seal (31) as well as spherical washers (33) and axial roller bearing (34) off the steering worm (35).

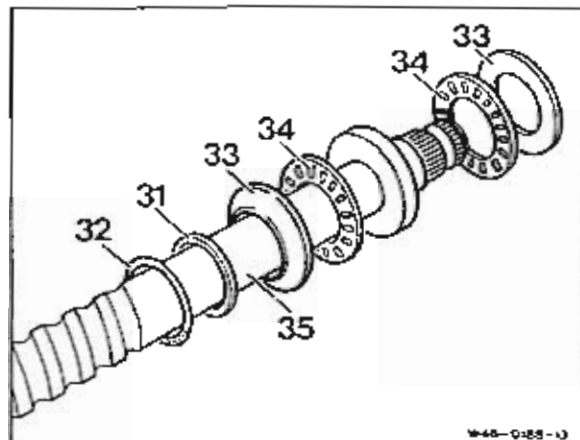

8 Remove locking ring (38) and radial seal (37) from the outer bearing insert (36).

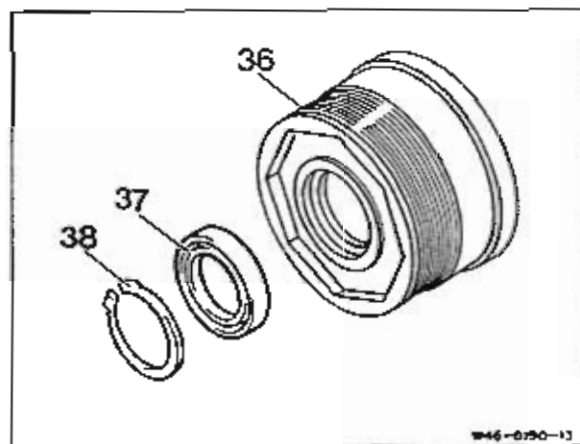

9 Remove needle bearing (30) from the inner bearing insert (29) using internal extractor.

Internal extractor 000 589 30 33 00

Counter-support 000 589 34 33 00

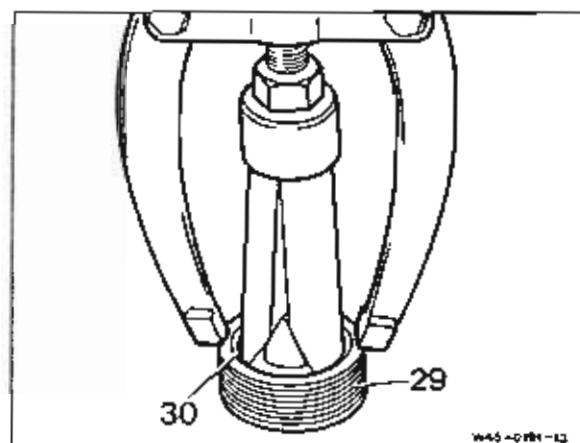

Assembly

Note:

When assembling or installing, moisten all sliding parts, in particular the bearings, with oil.

- 1 Press needle bearing (30) into the inner bearing insert (29) with a suitable sleeve.
- 2 Insert Teflon seal (31) with the O-ring (32) located below it, into the inner bearing insert (29).

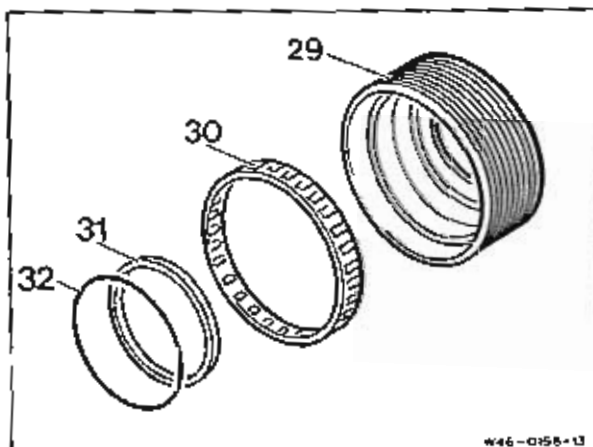

- 3 Fit axial roller bearing (34), spherical washer (33) and inner bearing insert (29) onto the steering worm (35) (arrow).

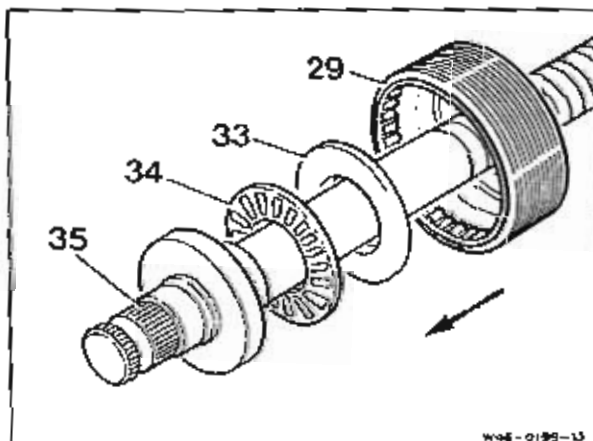

- 4 Measure friction torque of steering worm (35) in the Teflon seal (31) of the inner bearing insert (29) using handwheel and torque bolt. Friction torque of steering worm in Teflon seal: 35 - 45 Ncm.

Handwheel 352 589 08 63 00

Torque wrench 001 589 80 21 00

- 5 Again remove inner bearing insert (29), spherical washer (33) and axial roller bearing (34).

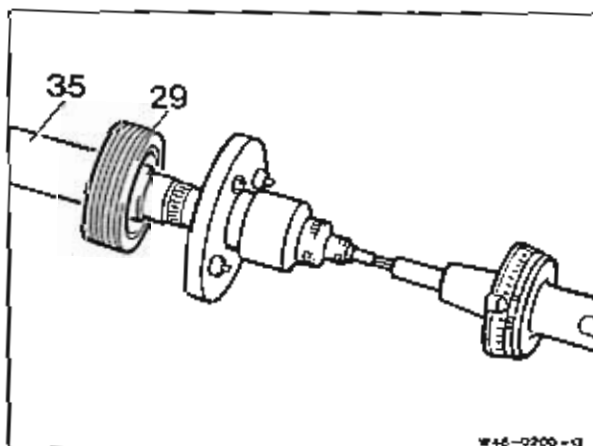

6 Press radial seal (37) into the outer bearing insert (36) with drift.

Drift 360 589 00 15 00

Note:

Pack radial seal (37) between dust lip and sealing lip with grease.

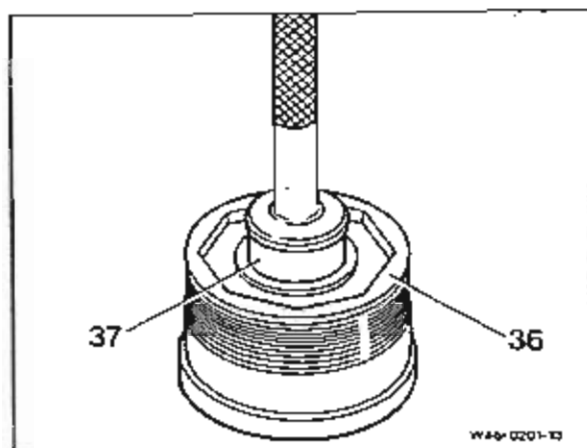

7 Install locking ring (38).

8 Fit axial roller bearing (34) and spherical washer (33) onto the steering worm (35).

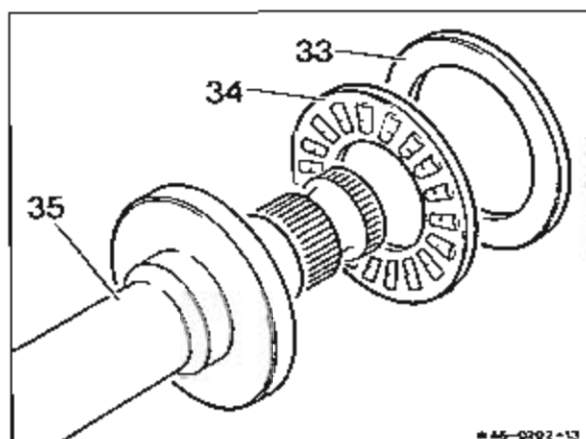

9 Fit assembly sleeve (A) onto the steering worm (35) and push onto the outer bearing insert (36).

Assembly sleeve (A) 352 589 01 61 00

Note:

Use assembly sleeve (A) in order to avoid damaging the radial seal.

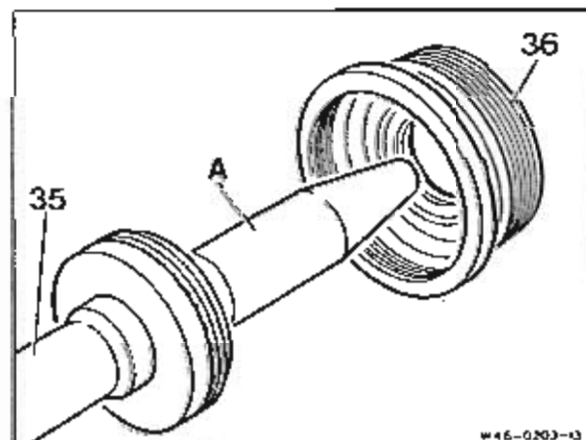

10 Measure friction torque of steering worm (35) in radial seal of outer bearing insert (36) using handwheel and torque wrench.
Friction torque of steering worm in radial seal:
15 - 20 Ncm.

Handwheel 352 589 08 63 00

Torque wrench 001 589 80 21 00

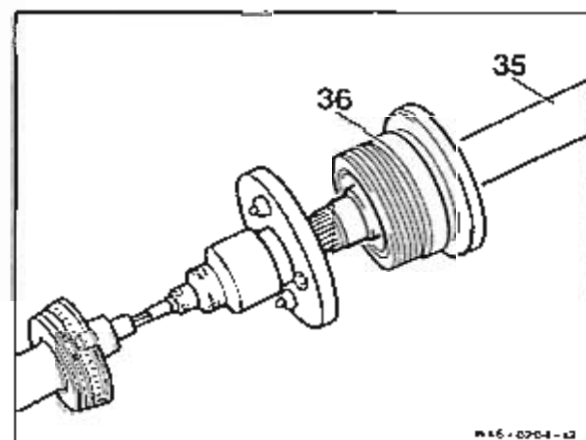

11 Fit outer bearing insert with steering worm into the retaining wrench.

Retaining wrench 387 589 00 31 00

12 Fit on axial roller bearing (34) and spherical washer (33).

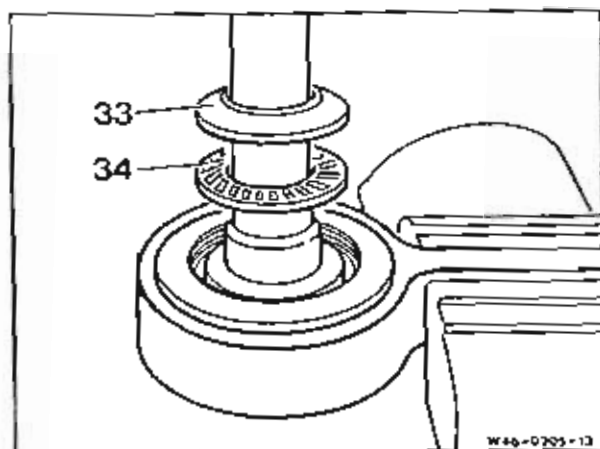

13 Screw inner bearing insert (29) into the outer bearing insert using the adjusting wrench until the axial bearings are making contact. Turn steering worm when performing this step to ensure the axial bearings are not twisted.

Adjusting wrench 387 589 00 07 00

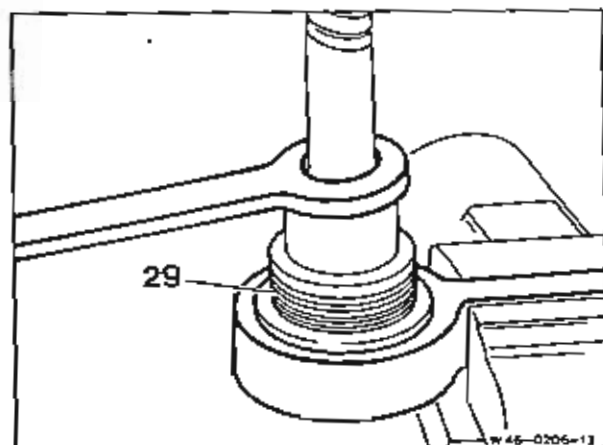

14 Screw slotted nut (28) onto the inner bearing insert, do not tighten at this stage (lock slightly).

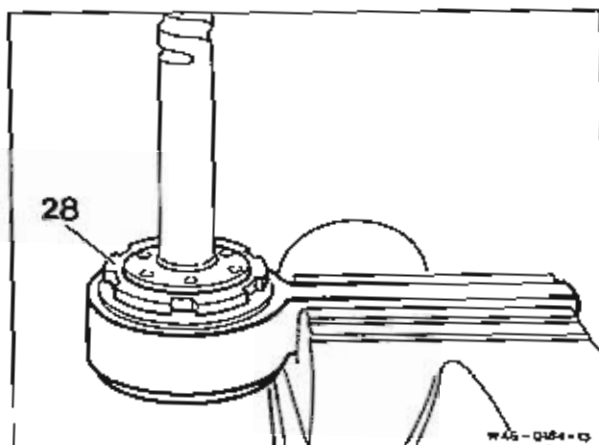

Arrangement of steering worm bearing

- 28 Slotted nut M72 x 1.5
- 29 Inner bearing insert
- 30 Needle bearing
- 31 Teflon seal
- 32 O-ring
- 33 Spherical washer
- 34 Axial roller bearing
- 35 Steering worm
- 36 Outer bearing insert
- 37 Radial seal
- 38 Locking ring

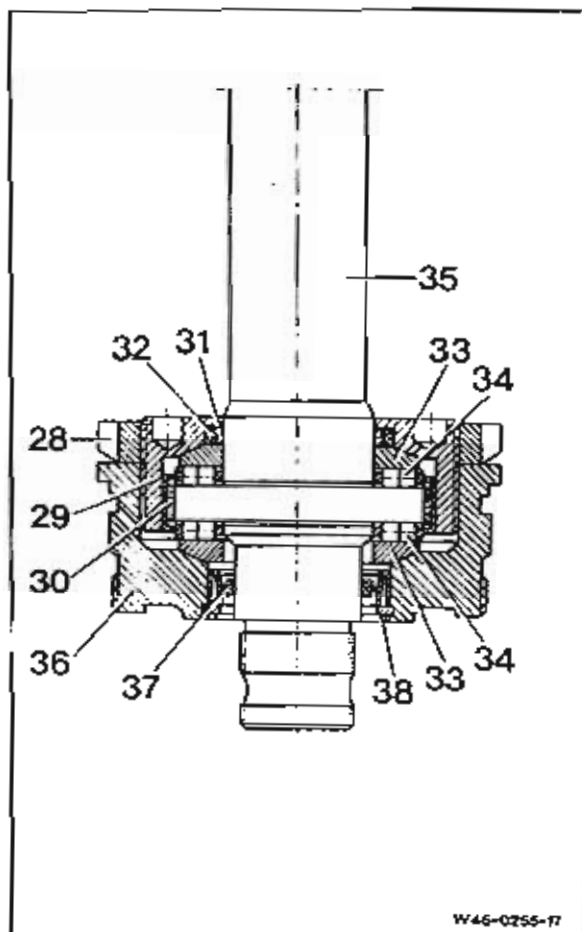

15 Measure total friction torque of steering worm bearing using torque wrench and handwheel.

Total torque of steering worm bearing:
75 – 80 Ncm.

Torque wrench 901 589 80 21 00

Handwheel 352 589 08 63 00

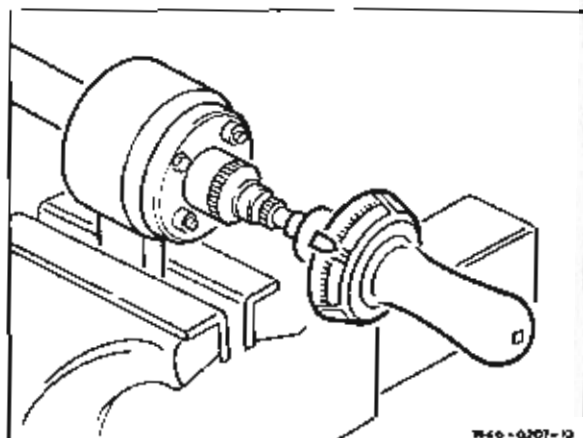

Note:

Friction torque of Teflon seal 35 – 45 Ncm plus friction torque of radial seal 15 – 20 Ncm plus friction torque of the axial bearings of 15 Ncm produces a total friction torque of 75 – 80 Ncm.

The friction torque can be corrected as follows by tuning the bearing insert and the slotted nut:

Measured value less than specified friction torque = tighten bearing insert.

Measured value greater than specified friction torque = slacken bearing insert.

16 Secure inner bearing insert by locking slotted nut (28) with adjusting wrench.

Adjusting wrench 387 589 00 07 00

Tightening torque of slotted nut (28) with adjusting wrench 230 Nm.

Note:

After locking the slotted nut, re-check the friction torque (axial bearings and seals); repeat setting, if necessary.

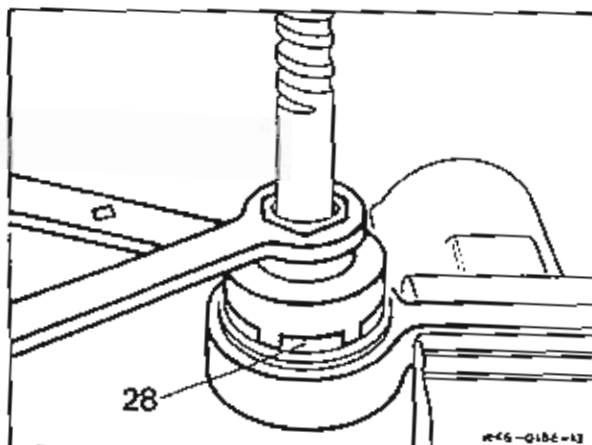

C Disassembling and assembling working piston and steering nut

Disassembly

1 Mount working piston (25) into assembly device.

Assembly device 352 589 00 31 00

2 Unscrew slotted nut (16) with pronged wrench.

Pronged wrench 352 589 02 07 00

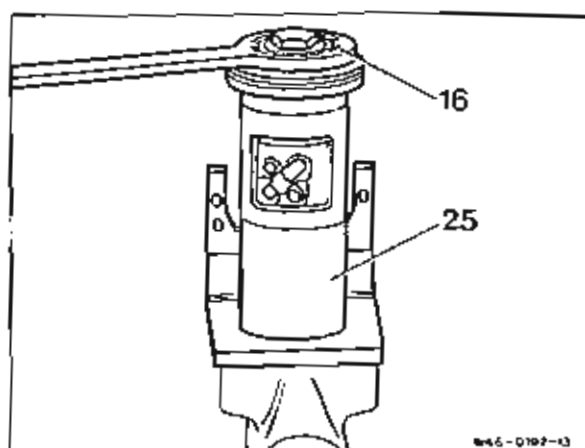

3 Remove screw cover (17) from the working piston (25) and take off spherical washer (18).

4 Remove Teflon seal (23) and O-ring (24).

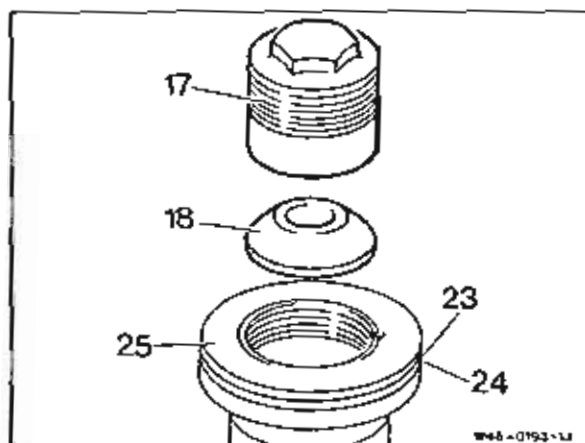

5 Remove Belleville spring washers (19, 20) as well as bearing race (21) and axial ball bearing (22) from the working piston (25).

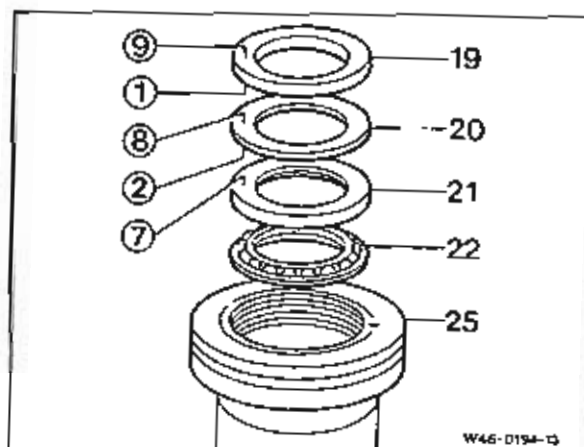

6 Take steering nut (7) out of the working piston (25). remove bearing race (6).

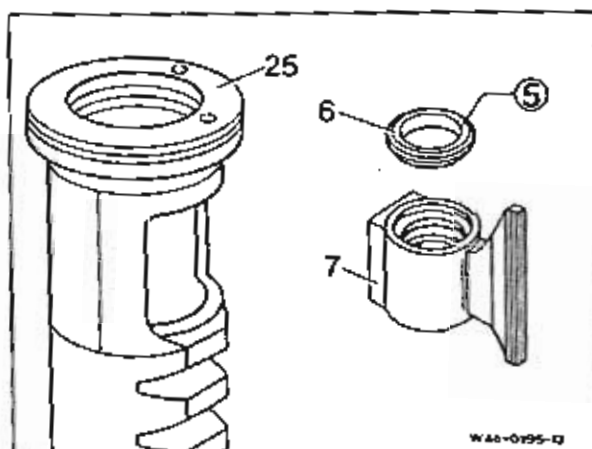

7 Take axial roller bearing (8), axial washer (9) and Belleville spring washers (10, 11) out of the working piston (25).

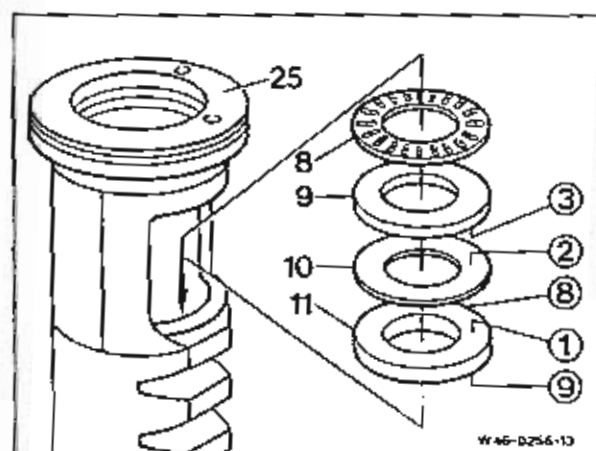

8 Remove tab washers (2), fixing clip (3) and ball guide halves (4) from the steering nut (7).

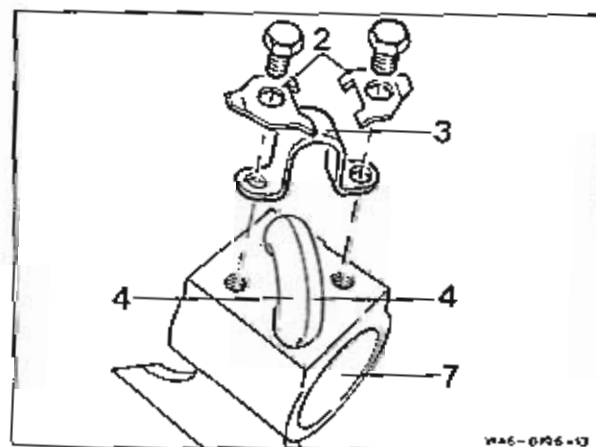

Assembly

Note:

When assembling or installing, moisten all sliding parts, in particular the bearings, with oil.

1 Check friction torque of the recirculating ball parts; insert steering worm into steering nut to perform this step. Fill one hole (arrow) of the steering nut with 20 balls. Constantly turn the steering worm when inserting the balls so that they can be moved on without any play. Turn steering worm into the steering nut far enough for the first ball to be visible in the second hole.

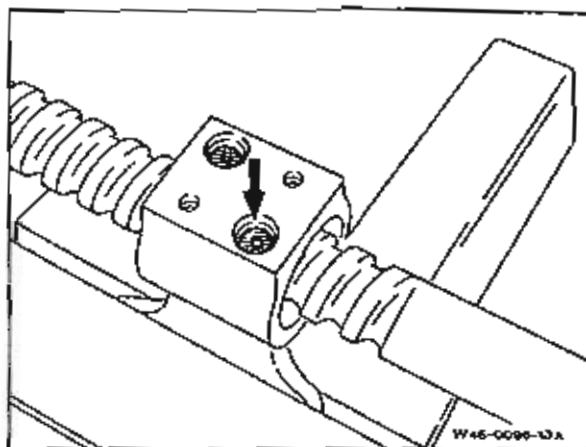

2 The remaining 8 balls are inserted into the ball guide half. To facilitate installation, insert the outer balls with a little grease (arrows). Insert filled ball guide halves into the bore of the steering nut.

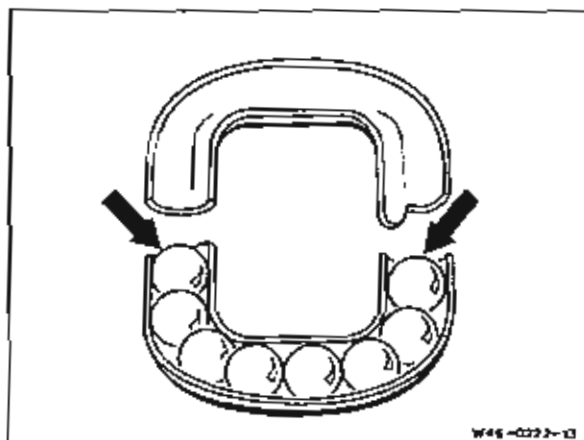

3 Fit on fixing clip (3) and screw tight.

4 Measure friction torque of the steering worm in the steering nut using torque wrench and handwheel.

Friction torque of recirculating ball part: 70 Ncm.

Handwheel 352 589 08 63 00

Torque wrench 001 589 80 21 00

Note:

If a check of a steering worm together with steering nut reveals that the friction torque is less than 20 Ncm, the steering worm must be renewed together with the steering nut and the balls.

5 After determining the friction torque, remove balls again from steering nut, take off ball guide halves (4) and fixing clip (3) by unscrewing steering worm.

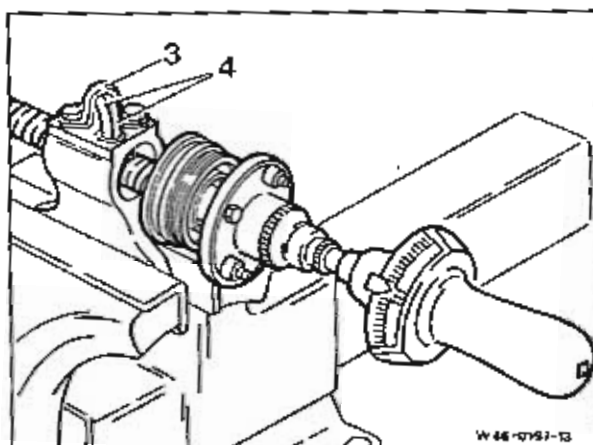

6 Insert Belleville spring washer (10, 11), axial washer (9) and axial roller bearing (8) into the working piston.

Note:

Ensure that the parts are fitted in the correct order and in the correct position.

The numbers stamped on the parts (numbers in circle) indicate the correct installation position.

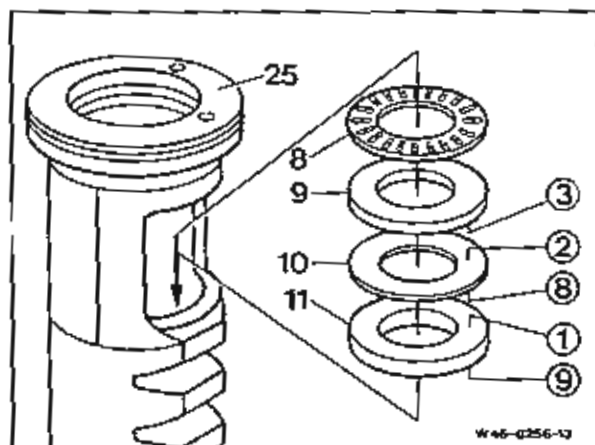

7 Install bearing race (6) into the steering nut (7) using a suitable drift.

Note:

Ensure that the parts are installed in the correct order and in the correct position.

The number stamped on the bearing race (number 5 in circle) indicates the correct installation position.

8 Install steering nut (7) in the working piston (25).

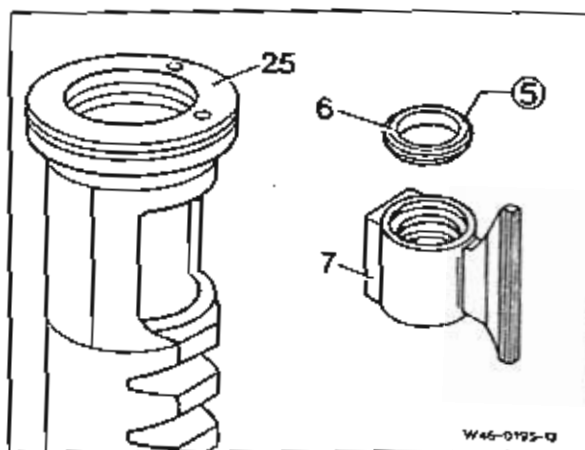

9 Insert axial ball bearing (22), bearing race (21), Belleville spring washers (20, 19) into the working piston (25).

Note:

Ensure that the parts are installed in the correct order and in the correct position.

The numbers stamped on the parts (numbers in circle) indicate the correct installation position.

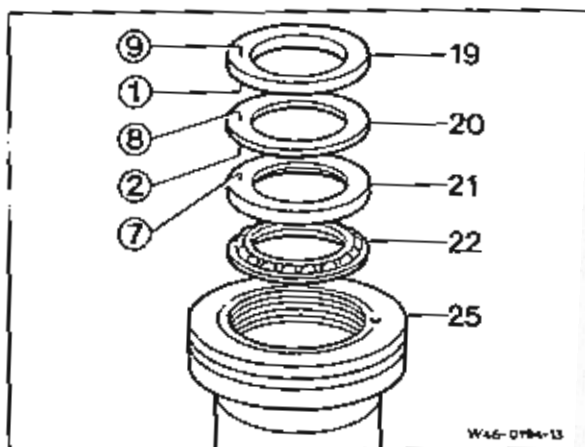

10 Insert thrust washer (18). Screw cover (17) into the working piston (25) until it is touching the bearing. Move steering nut back and forward at the straightedge when performing this step to ensure that the axial bearings are not twisted.

11 Insert O-ring (24) and Teflon seal (23) into the radial groove on the working piston (25). To facilitate installation, place Teflon seal into a mixture of warm water and a few drops of oil before installing.

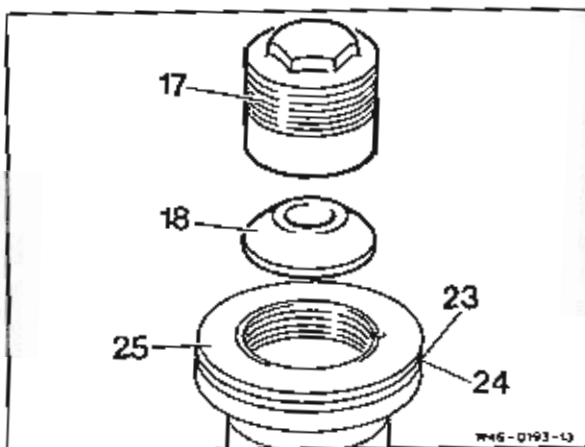

Arrangement of steering nut bearing

- 6 Bearing race
- 7 Steering nut
- 8 Axial roller bearing
- 9 Axial washer
- 10 Belleville spring washer
- 11 Belleville spring washer
- 16 Slotted nut
- 17 Screw cover
- 18 Spherical washer
- 19 Belleville spring washer
- 20 Belleville spring washer
- 21 Bearing race
- 22 Axial ball bearing
- 23 Teflon seal
- 24 O-ring
- 25 Working piston

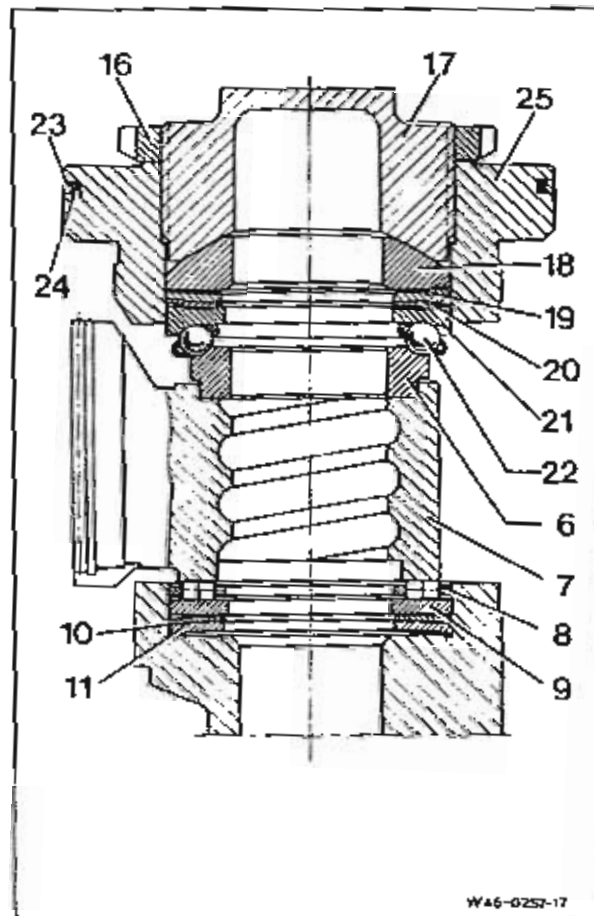

12 Place working piston into the assembly device. Screw on slotted nut (16) and lightly lock screw cover (17) with pronged wrench.

Assembly device 352 589 00 31 00

Pronged wrench 352 589 02 07 00

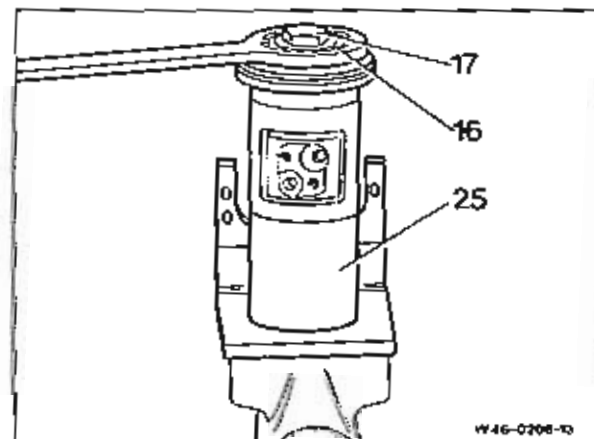

13 Check and adjust friction torque of the steering nut in the working piston. Tension test device on the straightedge of the steering nut. Insert torque wrench and check friction torque (not breakaway torque).

Friction torque of steering nut in working piston:
25 Ncm.

Torque wrench 001 589 80 21 00

Test device 363 589 01 21 00

Note:

If the specified friction torque is not achieved, it must be corrected by turning the screw cover and the slotted nut:

Measured value less than specified friction torque = tighten screwcover.

Measured value greater than specified friction torque = slacken screwcover.

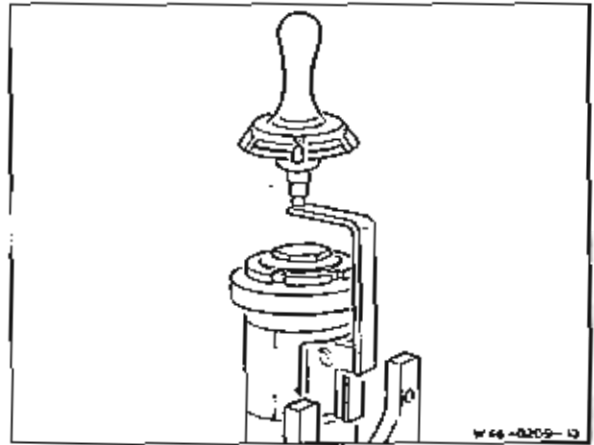

14 Secure screwcover (17) by tightening slotted nut (16) with pronged wrench (17). Hold screwcover (17) tight with wrench socket to prevent it moving.

Tightening torque of slotted nut is 270 Nm.

Note:

After locking the slotted nut, re-check friction torque; repeat setting if necessary.

The friction torque should be checked with the greatest care as proper operation of the steering depends essentially on this setting.

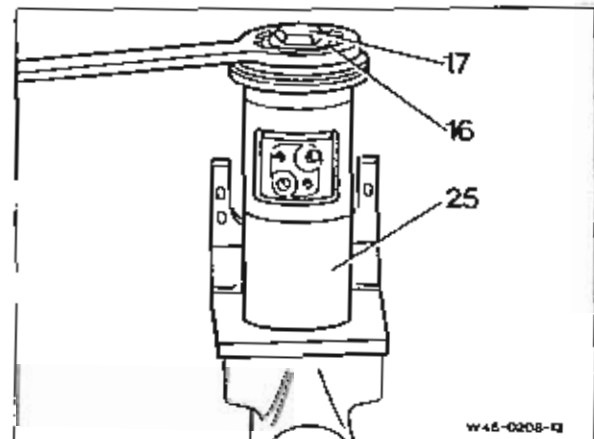

Pronged wrench 352 589 02 07 00

D Installing steering worm with bearing into working piston

Note:

When assembling or installing, moisten all sliding parts, in particular the bearings, with oil.

1 Introduce steering worm (35) into the working piston (25).

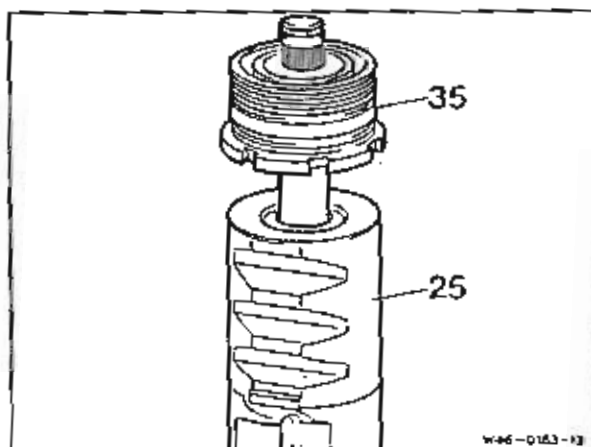

2 Fill 20 balls into one hole (arrow) of the steering nut. Constantly turn on steering worm when performing this step to ensure that the balls are carried forward without play. Turn steering worm far enough into the nut until the first ball is visible in the second opening.

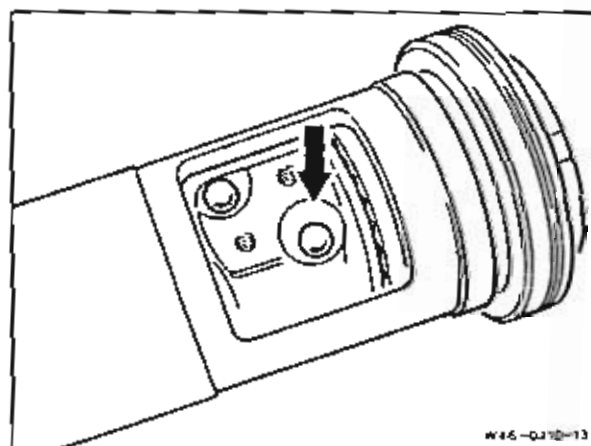

3 The remaining 8 balls are inserted in the ball guide half. To facilitate installation, insert the outer balls with a little grease (arrows). Insert filled ball guide halves into the bore of the steering nut.

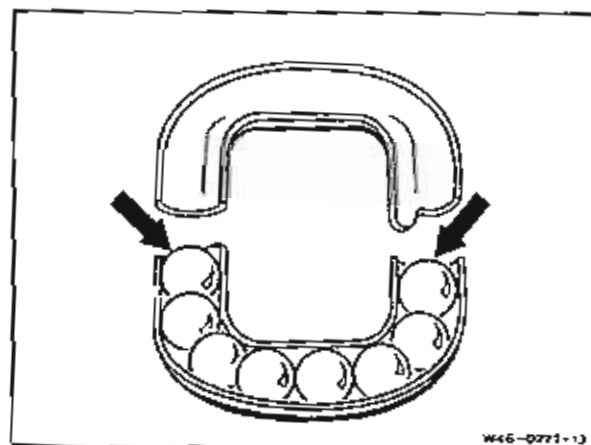

4 Screw ball guide halves (4) tight to the steering nut with tab washers (2).

Note:

After inserting the balls, turn steering worm fully into the working piston.

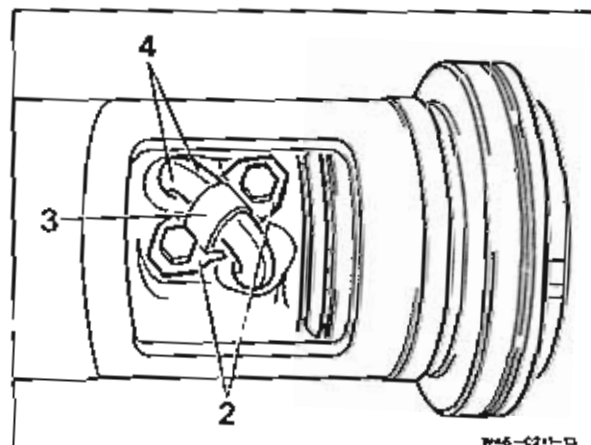

E Installing working piston with steering worm

Note:

When assembling or installing, moisten all the sliding parts, in particular the bearings, with oil.

1 Insert working piston (25) into the steering housing (26) and carefully introduce into the housing groove and also into the valve spool with the straightedge of the steering nut.

Note:

Do not press the straightedge of the steering nut into the valve spool with force to ensure that the edge at the recess of the valve spool is not damaged.

Push working piston in far enough for the inner bearing set of the axial bearings to be properly located in the steering housing.

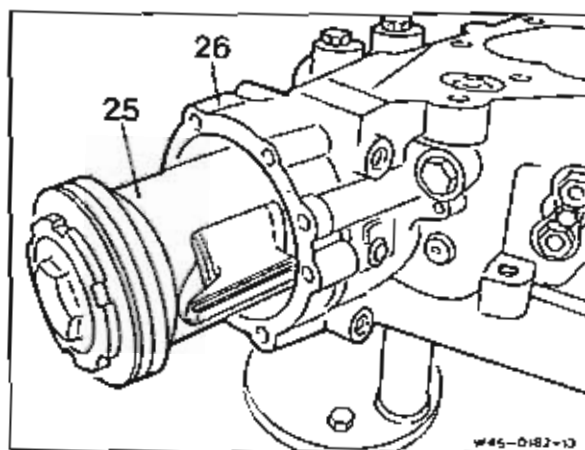

2 Screw slotted nut (27) onto the bearing insert and screw tight with pronged wrench and wrench socket to 450 - 500 Nm.

Pronged wrench 352 589 01 07 00

Wrench socket 385 589 01 03 00

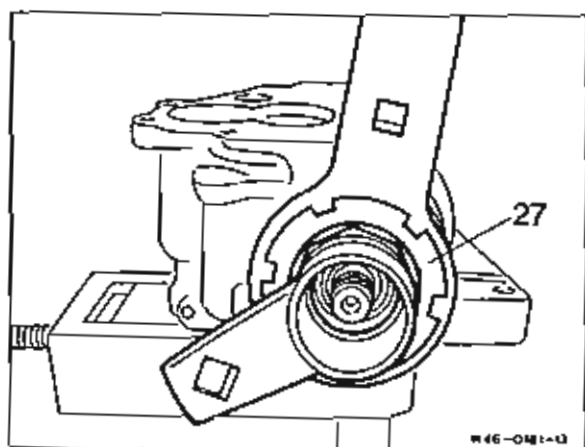

3 Insert O-ring (15) into the bottom housing cover (14). Bolt housing cover (14) tight to steering housing (26) with hexagon bolts (12).

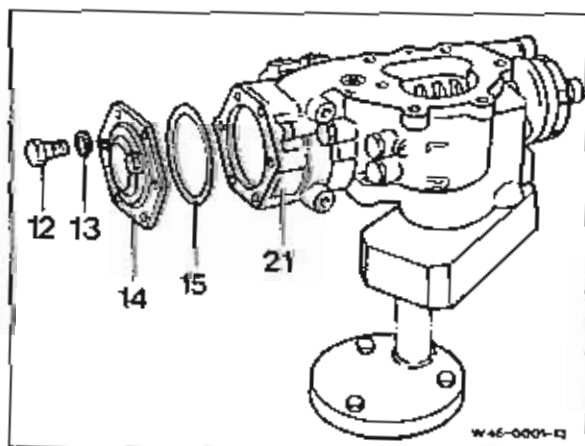

46.7-080 Removing, disassembling, assembling and installing valve spool

Preceding work

Working piston removed (46.7-075)

Note:

If the control edges are damaged, the valve spool must be replaced together with the housing.

It is only necessary to disassemble the valve spool for cleaning purposes. The valve spool and all the components are not available as a replacement part.

A Model Designation 765.200 and 765.300

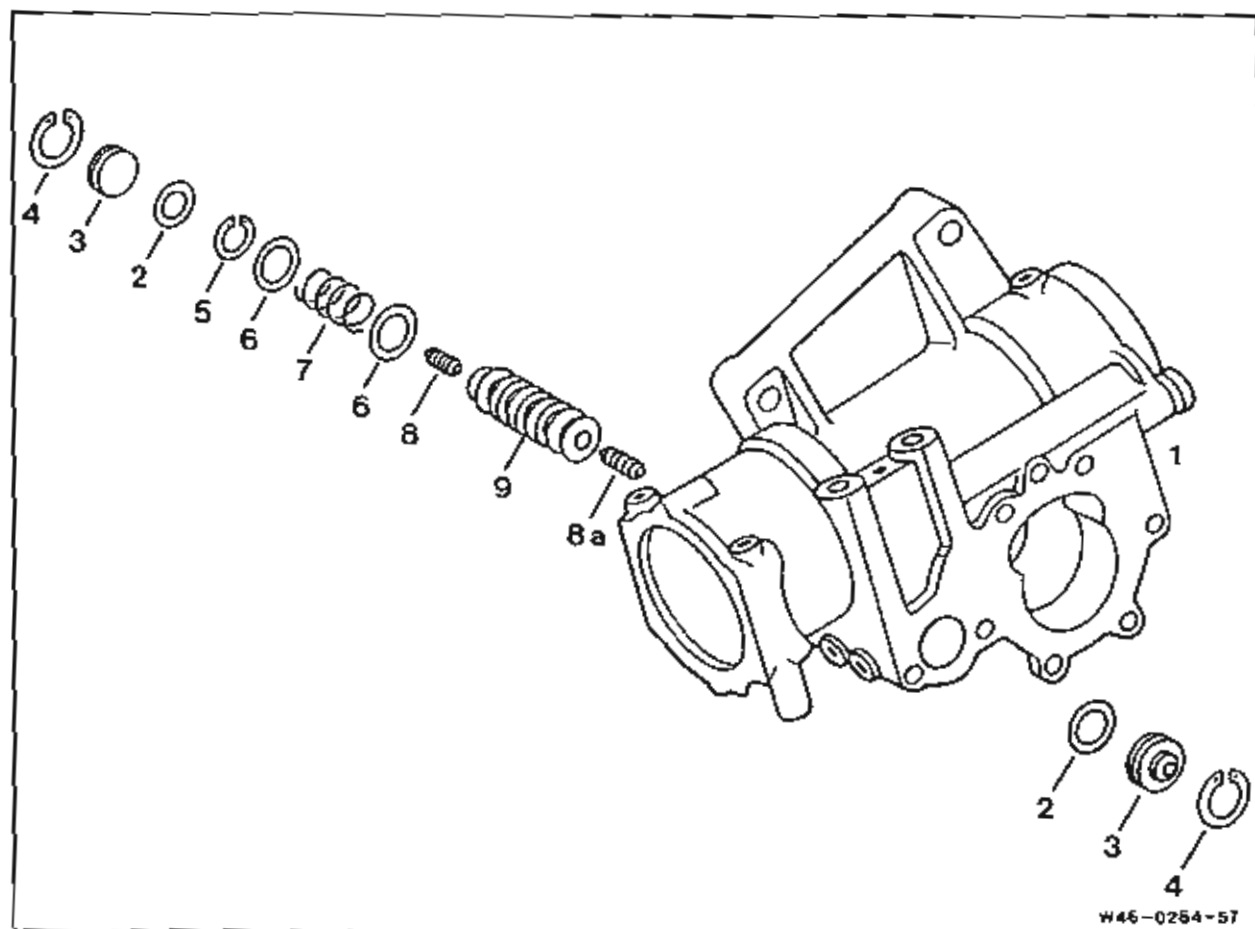

- 1 Steering housing
- 2 Seal renew
- 3 End cover
- 4 Locking ring
- 5 Locking ring
- 6 Thrust washer
- 7 Basic load spring
- 8 Reaction piston
- 9 Valve spool

Removal

1 Remove locking rings (4), end cover (3) together with seals (2) from the steering housing.

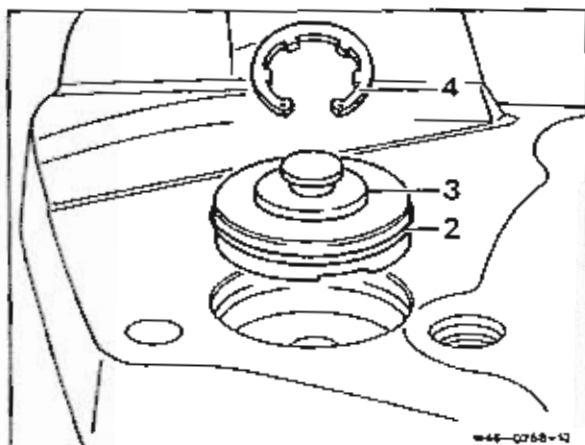

2 Carefully withdraw valve spool from the steering housing. Perform this step with the greatest care as the valve spool is lapped into the steering housing.

Note:

The control edges of the valve spool must not be damaged.

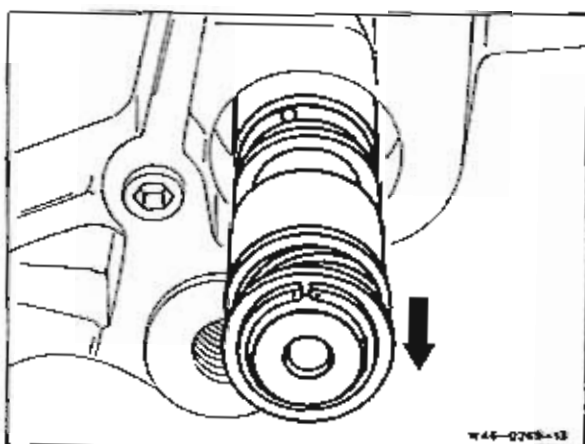

Disassembly

1 Take locking ring (5) and basic load spring (7) (pay attention to spring tension) together with thrust washers (6) off the valve spool (9).

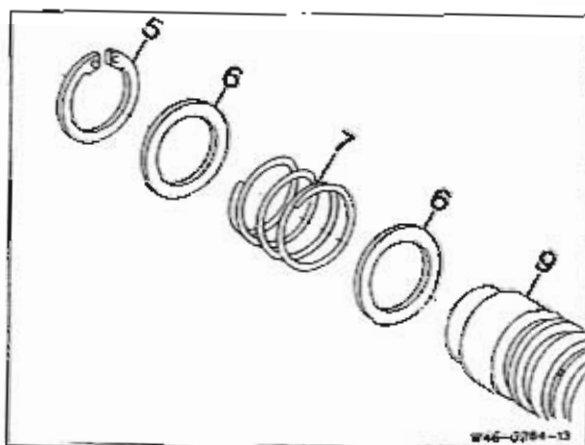

2 Remove reaction pistons (8, 8a) from the valve spool and mark without damaging.

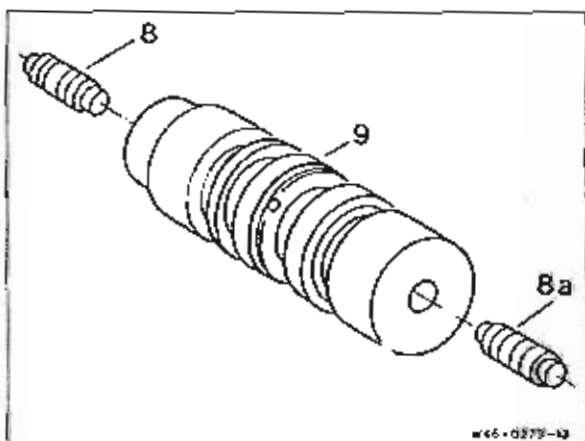

Cleaning and assembling

1 Clean all parts carefully and blow out holes with compressed air. Examine control edges for signs of damage. If damage exists, the valve spool must be renewed together with steering housing.

Arrangement of valve spool

- 1 Steering housing
- 2 Seal
- 3 End cover
- 4 Locking ring
- 5 Locking ring
- 6 Thrust washer
- 7 Basic load spring
- 8 Reaction piston
- 8a Reaction piston
- 9 Valve spool

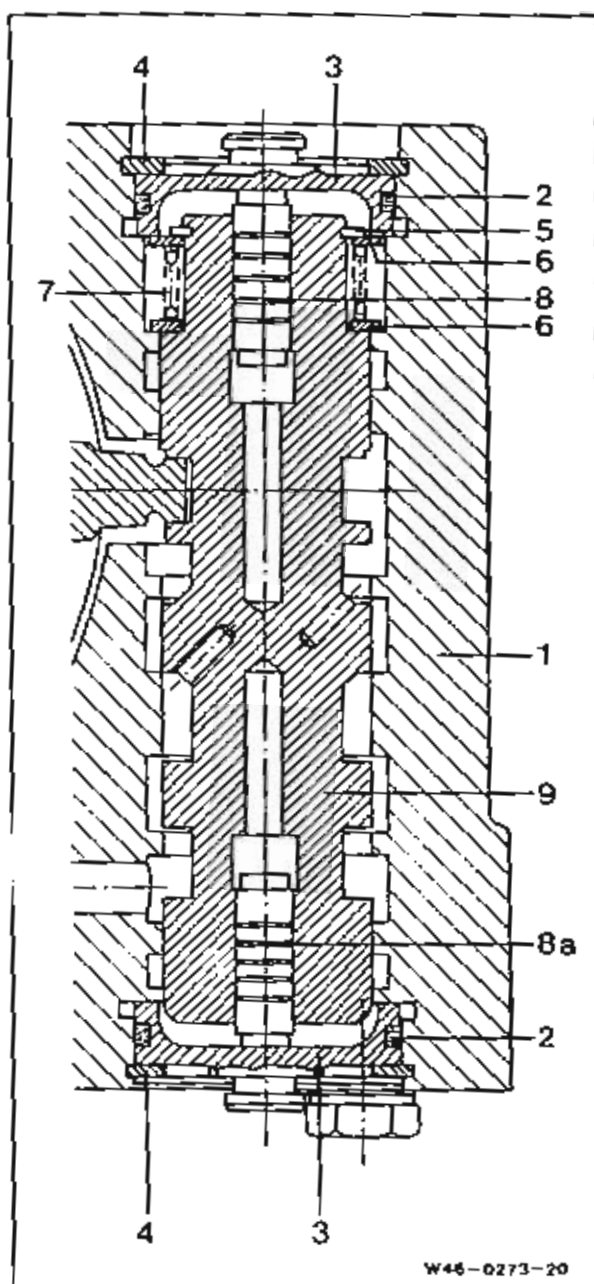

2 Install reaction pistons (8, 8a) into the valve spool (9).

Pay attention to marking!

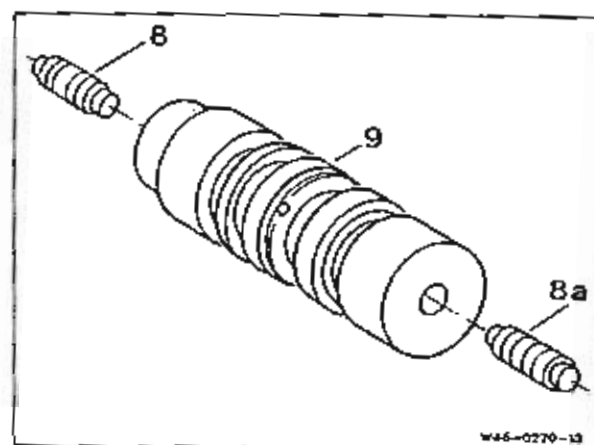

3 Fit basic load spring (7) together with thrust washers (6) onto the valve spool (9) and secure with locking ring (5).

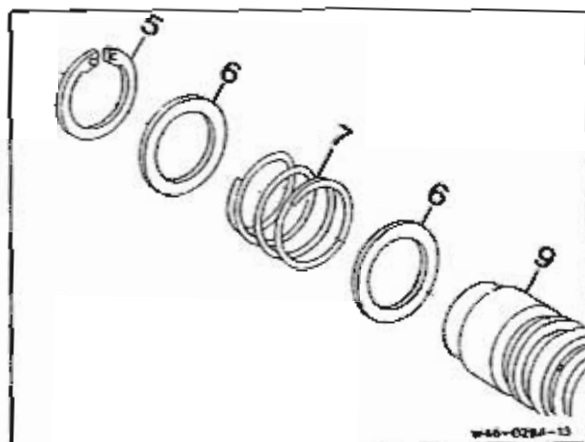

Installation

1 Carefully insert valve spool into the steering housing.

Note:

When installing the valve spool, use the greatest care as the valve spool is lapped into the steering housing. If the control edges are damaged, both parts must be replaced together.

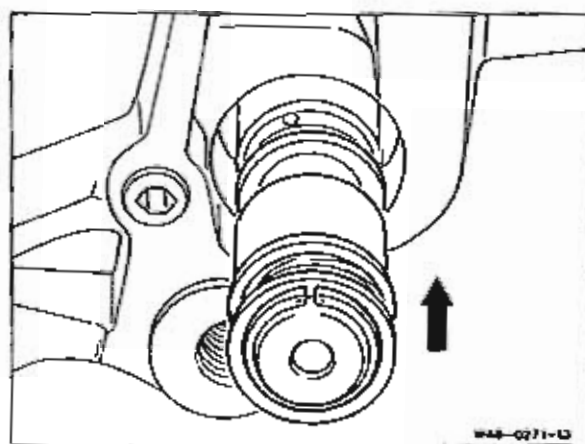

2 Insert end cover (3) with new seal (2) on both sides into the steering housing and secure with locking ring (4).

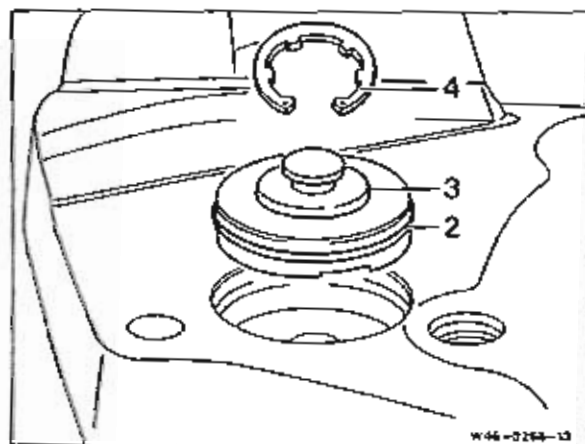

Arrangement of locking ring (4)

- 2 O-ring
- 3 Cover
- 4 Locking ring
- 5 Locking ring
- 6 Thrust washer
- 7 Basic load spring

Note:

Ensure that the locking ring (4) is installed in this position (arrow). If the locking ring is improperly installed, the hydraulic steering assistance will fail.

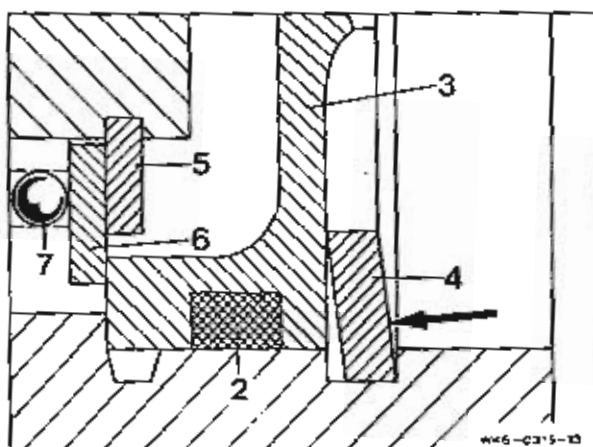

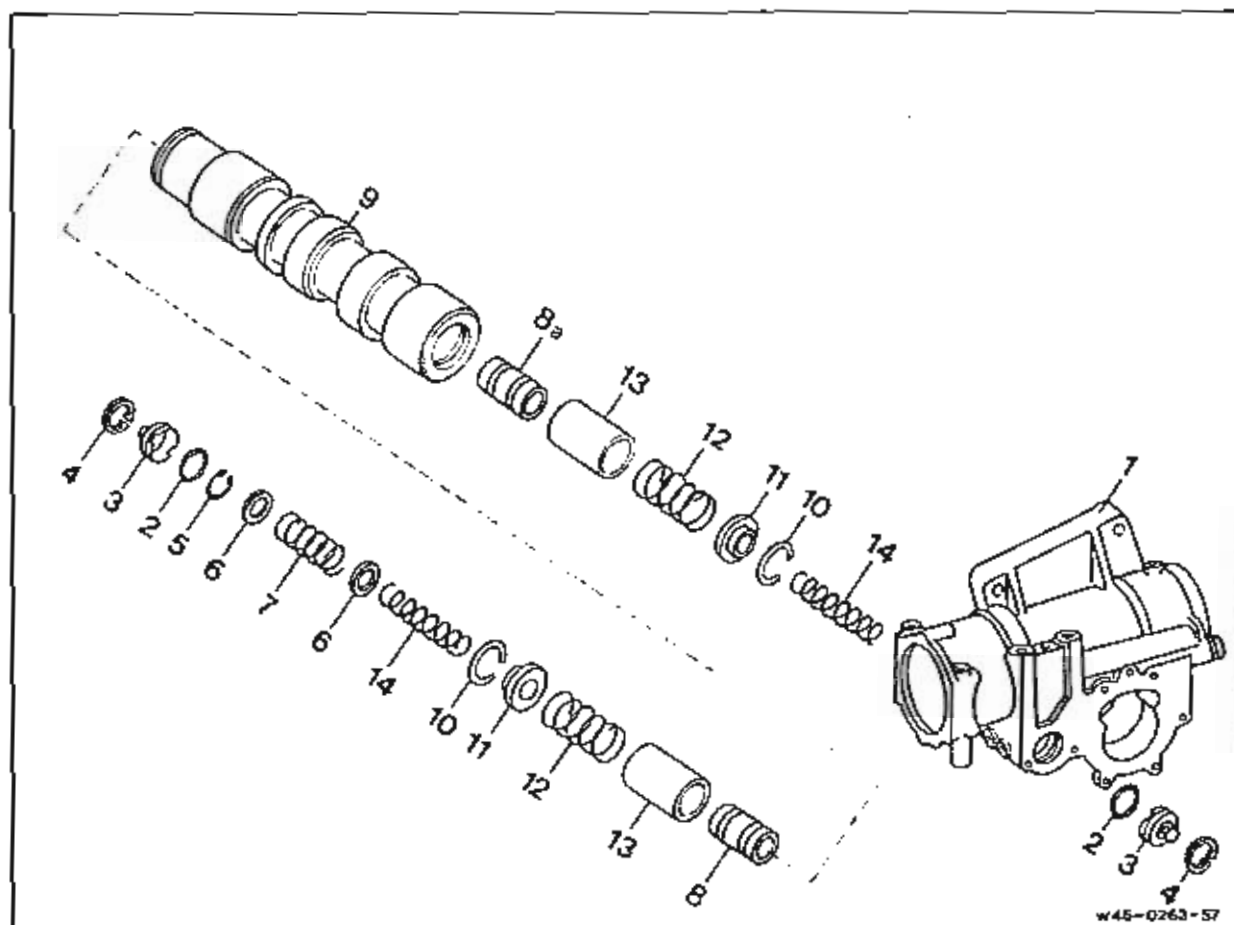

- 1 Steering housing
- 2 Seal renew
- 3 End cover
- 4 Locking ring
- 5 Locking ring
- 6 Thrust washer
- 7 Basic load spring
- 8 Reaction piston
- 8a Reaction piston
- 9 Control valve
- 10 Locking ring
- 11 Guide ring
- 12 Compression spring
- 13 Guide bush
- 14 Compression spring

Removal

1 Remove locking rings (4), and cover (3) together with seals (2) from the steering housing.

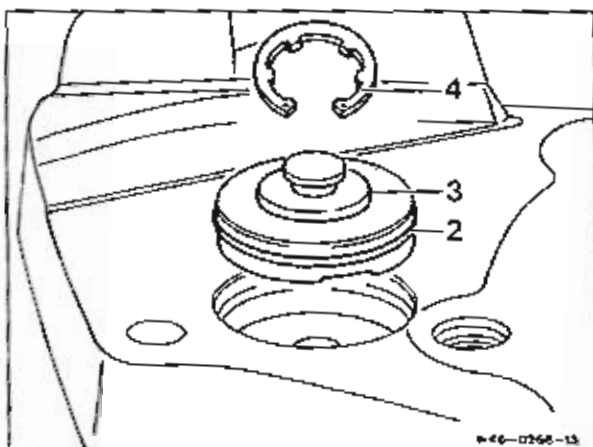

2 Carefully withdraw valve spool from the steering housing. Perform this step with the greatest care as the valve spool is lapped into the steering housing.

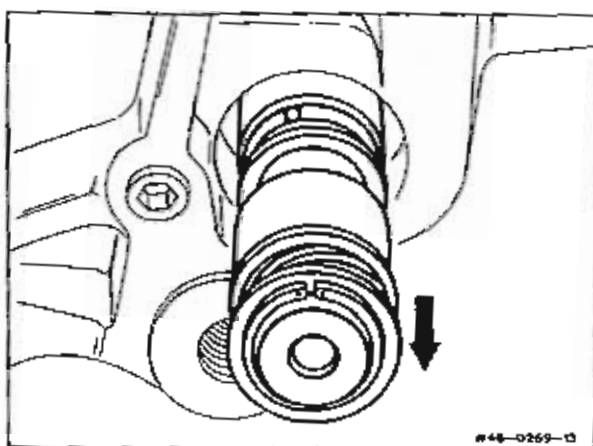

Disassembly

1 Take locking ring (5) and basic load spring (7) (pay attention to spring tension) together with thrust washers (6) off the valve spool (9).

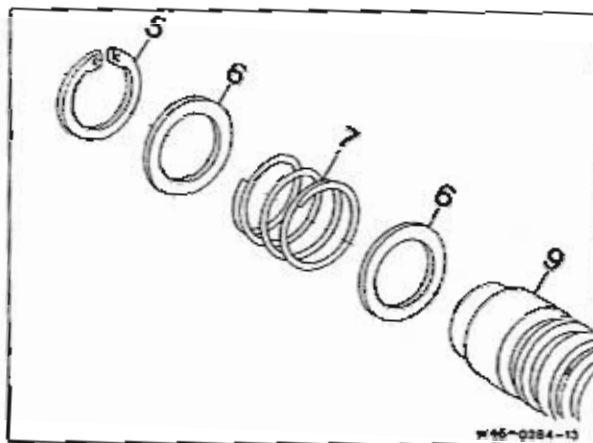

2 Take out compression springs (14). Remove locking rings (10). Take guide rings (11), compression springs (12), guide bushes (13) and reaction pistons (8, 8a) out of the valve spool (9). Mark reaction pistons (8, 8a) together with items 10 - 14 without damaging.

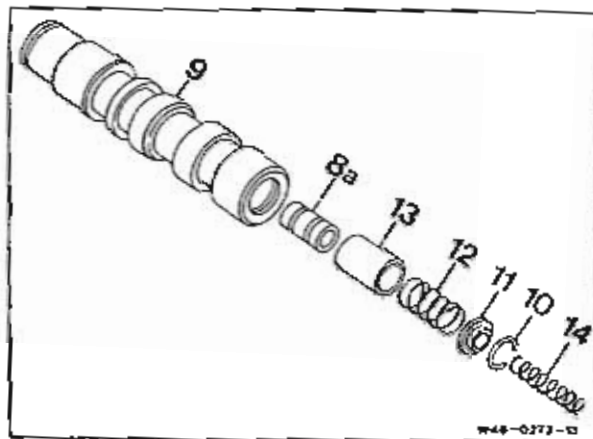

Cleaning and assembling

1 Clean all parts carefully and blow out holes with compressed air. Examine control edges for signs of damage. If damage exists, the valve spool must be renewed together with the steering housing.

Arrangement of valve spool

- 1 Steering housing
- 2 Seal
- 3 End cover
- 4 Locking ring
- 5 Locking ring
- 6 Thrust washer
- 7 Basic load spring
- 8 Reaction piston
- 8a Reaction piston
- 9 Valve spool
- 10 Locking ring
- 11 Guide ring
- 12 Compression spring
- 13 Guide bush
- 14 Compression spring

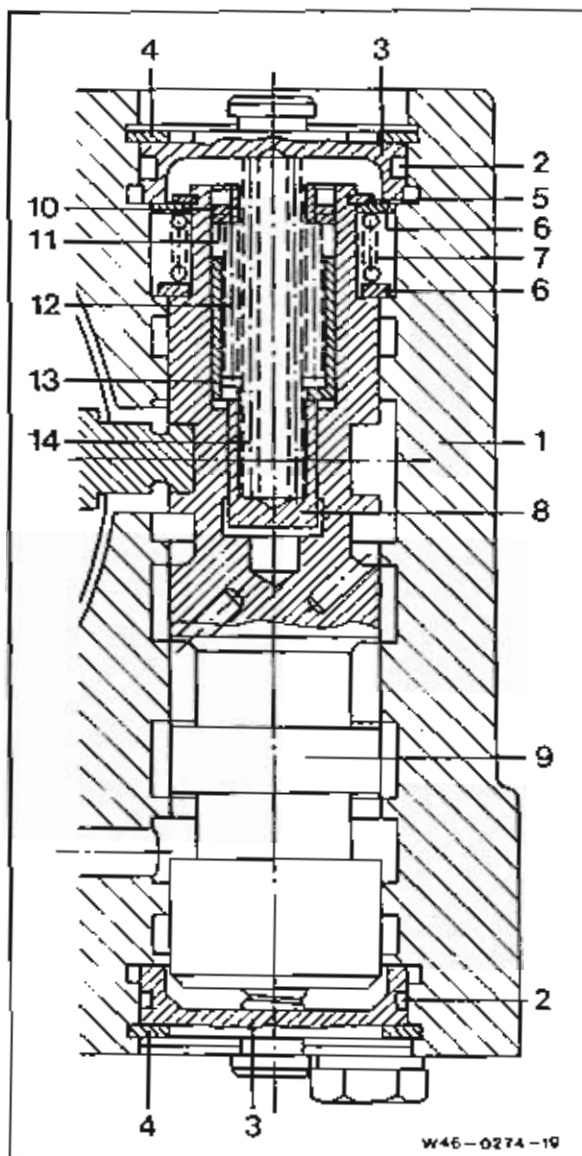

2 Install reaction pistons (8, 8a) together with items 10 - 14 into the valve spool (9). Pay attention to marking!

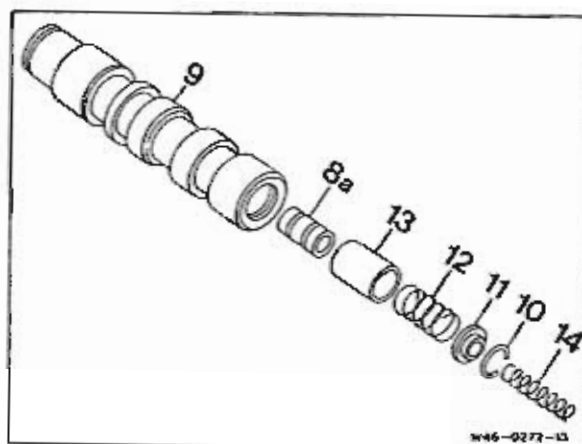

3 Fit basic load spring (7) together with thrust washers (6) onto the valve spool (9) and secure with locking ring (5).

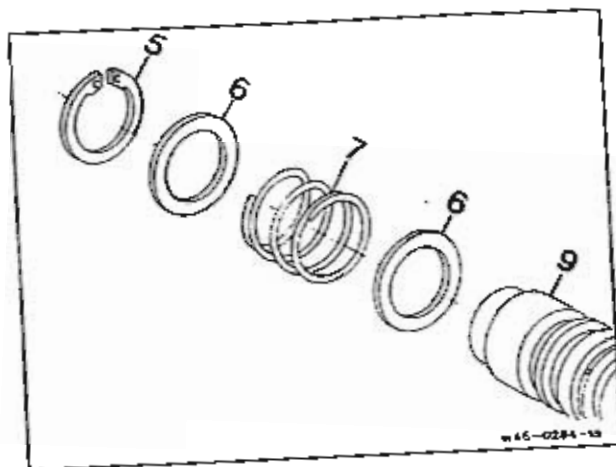

Installation

1 Carefully insert valve spool into the steering housing.

Note:

When installing the valve spool, use the greatest care as the valve spool is lapped into the steering housing. If the control edges are damaged, both parts must be replaced together.

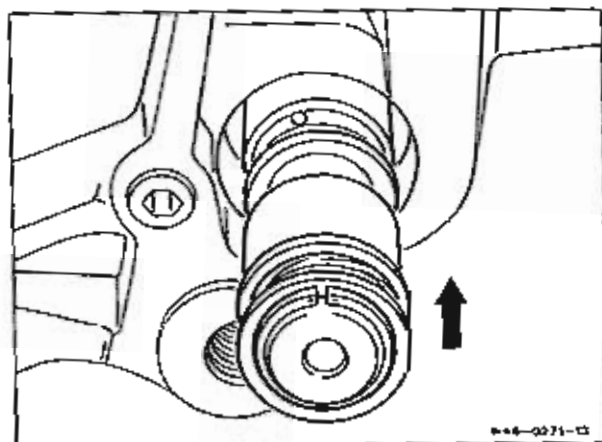

2 Insert end cover (3) with new seal (2) on both sides into the steering housing and secure with locking ring (4).

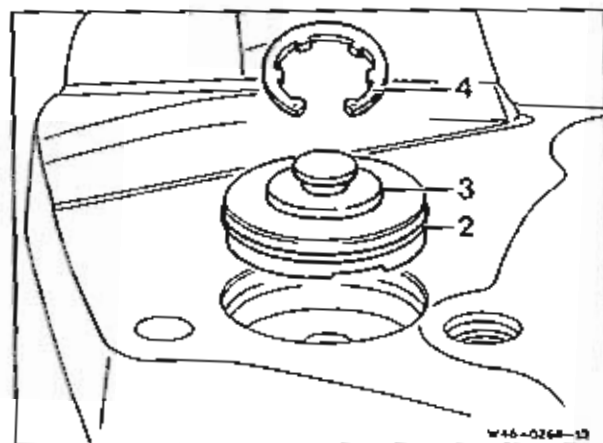

Arrangement of locking ring (4)

- 2 O-ring
- 3 Cover
- 4 Locking ring
- 5 Locking ring
- 6 Thrust washer
- 7 Basic load spring

Note:

Ensure that the locking ring (4) is installed in this position (arrow). If the locking ring is improperly installed, the hydraulic steering assistance will fail.

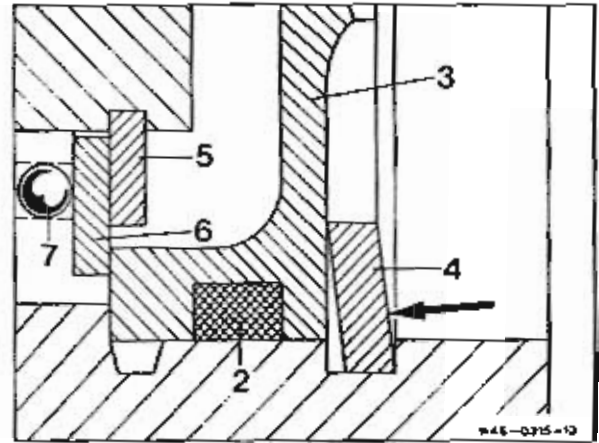

46.7-085 Removing and installing non-return valve

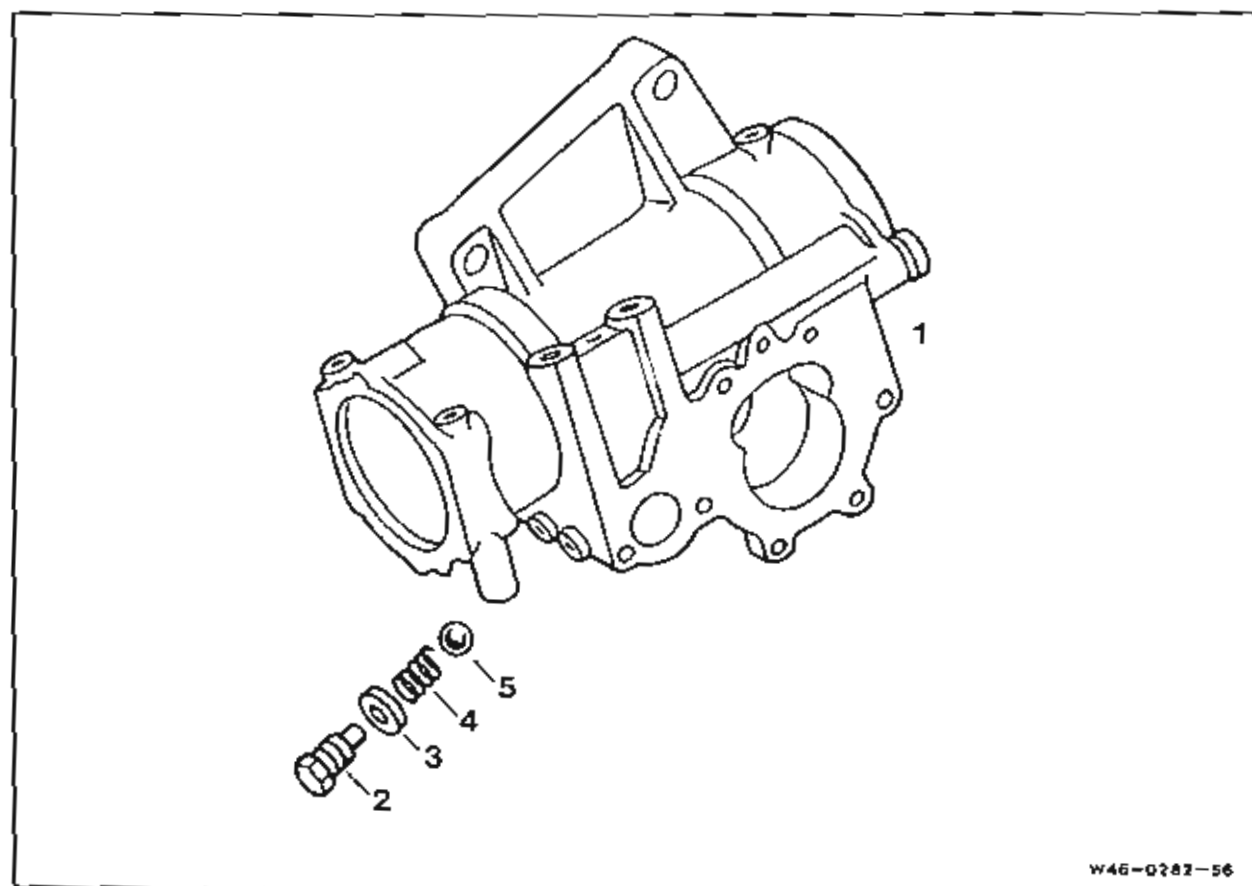

- 1 Steering housing
- 2 Collar bolt unscrew
- 3 Sealing ring renew
- 4 Spring
- 5 Ball

Revision Note

This microfilm replaces microfilm Z 5 5306 01 1.

The entire scope of LS5 F / LS7 F has been revised and the illustrations converted from matrix to line version.

Contents Steering LS 3, LS 5 F / LS 7 F

46.21 Steering LS 3 (765.6)

	Job. No.	Coordinates
Installation Survey	46.21 - 002/1	B 1
Illustrations, Exploded Views	46.21 - 003/1	D 1
Special Tools	46.21 - 004/1	K 1
Technical Data, Oil Capacity	46.21 - 005/1	L 1

Maintenance Work

Oil change	46.21 - 006/1	N 1
Checking and adjusting center position	46.21 - 006/3	A 2
Adjusting steering shaft	46.21 - 006/3	A 2
Checking play and wear	46.21 - 006/5	D 2

Inspection

Diagram for connecting test set	46.21 - 007/1	E 2
Connecting test set	46.21 - 007/2	G 2
Testing power steering pump for pressure	46.21 - 007/2	G 2
Testing delivery of power steering pump	46.21 - 007/3	H 2
Testing steering for pressure	46.21 - 007/4	K 2
Testing steering for leak oil	46.21 - 007/4	K 2
Testing and adjusting steering limit	46.21 - 007/6	N 2
Removing and installing steering	46.21 - 050/1	B 3
Inspecting steering components	46.21 - 060/1	H 3
Removing and disassembling steering shaft	46.21 - 070/1	K 3
Reassembling and installing steering shaft	46.21 - 080/1	O 3
Removing and disassembling steering worm and working piston ..	46.21 - 090/1	E 4
Reassembling and installing steering worm and working piston ..	46.21 - 100/1	N 4
Removing and installing valve spool	46.21 - 110/1	K 5
Checking and adjusting total actuating torque of steering	46.21 - 120/1	O 5

